



**OFFICE OF BUSINESS SERVICES
PHYSICAL EDUCATION BUILDING POOL STAIR 4 REPAIR
ROCKVILLE CAMPUS
RFP NO.: E621-004
RFP CLOSING DATE AND TIME: FEBRUARY 22, 2021 @ 2:00 PM**

**Addendum No. 1
Issued: February 17, 2021**

THIS ADDENDUM IS BEING ISSUED TO PROVIDE ANSWERS TO THE FOLLOWING QUESTIONS.

Item 1-1 Question: Note #10, Post-Installed Anchors & Rebars/S000: "Existing reinforcing bars within concrete substrate must be located and not cut unless SER indicates that bars may be cut". Is there a GPR or X-Ray requirement at any location prior to installing epoxy anchors or cutting slab for the placement of the new thickened slab at the bottom of the new stair, or at any other location? We don't really see this necessary, but we would like clarification.

Answer: Post-installed anchors: it is a requirement to scan for and avoid reinforcing where the stair attaches to the existing walls.

Item 1-2 Question: Note #3, Testing and Inspections/S000: "Cast and test cylinders of all concrete, mortar and grout to confirm the required 28 day minimum strength..." Are cylinder tests required for this project?

Answer: Cylinder tests can be eliminated from Contractor scope. Mix design submittal shall be submitted to SER for review and approval, and rebar needs to be inspected by SER prior to pour.

Item 1-3 Question: Detail D/S120: Calls for DUR-O-Wal @ 16" vertical. Could you specify what type of DUR-O-WAL reinforcement is to be used? Truss-Dur-O-Wal is for horizontal reinforcement installed typically every 2 rows of CMU, not @16" vertical. Dur-O-Eye is typically used every 16" O.C. but when brick veneer or similar is installed along with the CMU.

Answer: Standard truss-type horizontal joint reinforcing is required in the masonry infill wall. The 16" spacing is a vertical spacing, resulting in every other course. Dur-o-wall (Hohmann & Barnard) 120 truss mesh is the basis-of-design product.

Item 1-4 Question: Details C & D/S121 calls for touching up the stainless post welds with cold galvanize. Is that a misprint? Should use the specified paint system?

Answer: This is not a mis-print. Stainless stain is not painted. Welds to stainless steel shall be touched up with cold galvanize coating. ZRC is the basis-of-design.

Item 1-5 Question: Detail G/S120: Tread covers MS-STC -12 (12" depth) McNichols rep is telling me they only make 9" and 10".

**OFFICE OF BUSINESS SERVICES
PHYSICAL EDUCATION BUILDING POOL STAIR 4 REPAIR
ROCKVILLE CAMPUS
RFP NO.: E621-004
RFP CLOSING DATE AND TIME: FEBRUARY 22, 2021 @ 2:00 PM**

Answer: Please delete 3/16" cover plate (MS-STC-12) from project scope.

Item 1-6 Question: "Items Required for All Technical Submissions" 002413-2, Part 1, 1.2 D-1: Submit a list of ceiling replacement and painting projects... Is this a requirement for this RFP?

Answer: Provide evidence of experience for tnemec coating. Ceiling experience is not required.

Item 1-7 Question: Is a hard copy of the bid package required to be delivered or mailed within 5 business days after the bid due date or is the electronic submission sufficient?

Answer: In addition to the electronic submission, a hard copy of the bid package is required to be delivered/mailed within five (5) business days after the RFP closing date.

Index of Attachments to Addendum No. 1

Specification sections or portions reissued in entirety: None

Drawings reissued in entirety: None.

Sketches: None

Items issued for informational purposes: None.



Patrick Johnson, MBA
Director of Procurement

Please **sign** below to acknowledge receipt of this Addendum and return with the **Technical Proposal submission**, to the following email address, on or prior to the submittal deadline date and time:
vendor.proposals@montgomerycollege.edu.

Failure to return this Acknowledgement of Addendum may deem a proposal nonresponsive.

Company Name

Authorized Signature

Date

Printed/Typed Signature



Request for Proposal

RFP No.: E621-004

**Physical Education Pool Stair 4 Repair
Rockville Campus**

Project No.: FP21-028

**Issue Date: January 29, 2021
Montgomery College
9221 Corporate Boulevard
Rockville, Maryland 20850**

TABLE OF CONTENTS

INTRODUCTORY INFORMATION

000101	Project Title Page
000110	Table of Contents

Div. 00 – PROCUREMENT AND CONTRACTING REQUIREMENTS

PROPOSAL REQUIREMENTS

001119	Invitation Letter of Request for Proposal
002113	Instructions to Contractors
002213	Supplementary Instructions to Contractors
002413	Required Submissions
003119	Information Available to Contractors
004213A	Technical Proposal Form (Part A)
004213B	Price Proposal Form (Part B)
004313	Bid Bond
004400	Verification of Examination of Site Conditions
004513	Contractor's Qualification Statement
004513I	Subcontractor Information Form
004539	Minority Participation Form
004540	Procurement Office Questionnaire
004541	Conflict of Interest Statement

CONTRACTING REQUIREMENTS

006113.13	Montgomery College Standard Performance Bond
006113.16	Labor and Material Payment Bond
006276	Application and Certificate for Payment
007200	Montgomery College General Conditions of the Contract
007300	Montgomery College Supplementary Conditions of the Contract

TECHNICAL SPECIFICATION SECTIONS & DRAWINGS

DRAWINGS

S000	General Notes & Abbreviations
S101	Pool Deck Repair Plans
S120	New Stair Plans and Details
S121	New Stair Plans and Details

END OF TABLE OF CONTENTS



Procurement Office, Central Services
 9221 Corporate Boulevard
 Rockville, Maryland 20850
 Phone: (240) 567-5292

REQUEST FOR PROPOSAL

No. **E621-004**
Technical and Price Proposals

DATE ENTERED	BID CLASS	PAGE	of
--------------	-----------	------	----

THIS IS NOT AN ORDER

MONTGOMERY COLLEGE

REQUEST FOR PROPOSAL
 RFP NO.: E621-004

PHYSICAL EDUCATION BUILDING POOL STAIR 4 REPAIR ROCKVILLE CAMPUS

It is the intent of this Request for Proposals (RFP) to provide Montgomery College with construction services to **repair Stair 4 at the Physical Education building pool area on the Montgomery College Rockville Campus, located at 51 Mannakee, Rockville, Maryland 20850**, in accordance with the terms, conditions, and specifications described herein.

This Request for Proposal will be conducted by using a single-step two envelope bidding procedure. **A submittal consisting of the Technical Proposal and Price Proposal are required when responding to this Request for Proposal. All proposals must be submitted electronically, in two separate PDF file attachments.** One attachment shall consist of the Technical Proposal, and the second attachment shall consist of the Price Proposal. Both attachments shall be sent together, in a single email. **Subject line of email must include the following: Offeror’s Response to RFP No. E621-004 Physical Education Building Pool Stair 4 Repair, Rockville Campus.**

Electronic proposals shall be sent to vendor.proposals@montgomerycollege.edu, by 2:00 p.m. on February 22, 2021 Eastern Standard Time (EST). Any proposal received at the above email address, after the EST submittal deadline, will be automatically rejected. Proposals sent to other email address other than the above specified will NOT be accepted.

In addition to the electronic proposal submission, one original hardcopy proposal, to include both technical and price proposals, must be mailed or delivered to: Montgomery College Central Receiving Dept. Attn.: Office of Procurement, 7602 Standish Place, Derwood, Maryland 20855. See **Section 002113 and Section 002413** for full detailed submission instructions.

Proposals must remain valid for **one hundred and twenty (120) days** from the proposal due date and prior to contract award. Upon contract award, prices must remain firm for the duration of the overall contract term.

All required submissions must accompany each proposal. Incomplete proposals may be deemed disqualified for further consideration and will not be reviewed.

RFP documents include Invitation Letter of Request for Proposal, Instructions to Contractors, Supplementary Instructions to Contractors, Required Submissions, Information Available to Contractors, Technical Proposal Form (Part A), Price Proposal Form (Part B), Bid Bond, Verification of Examination of Site Conditions, Contractor’s Qualification Statement, Subcontractor Information Form, Minority Participation Form, Procurement Office Questionnaire, Conflict of Interest Statement, Montgomery College Standard Performance Bond, Labor and Material Payment Bond, Application and Certificate for Payment, Montgomery College General Conditions of the Contract, Montgomery College Supplementary Conditions of the Contract, Technical Specifications and Drawings, Appendices and all Addenda if any.

An electronic PDF version of RFP documents may be obtained by downloading the file from the College Procurement website at <http://www.montgomerycollege.edu/procure/> on or after **January 29, 2021**, at no charge.

No Pre-Proposal Conference will be held. **A site examination will be held at the project site at 11 a.m. on February 10, 2021. Site examination is mandatory and verification of the examination by a College representative is required.** Potential contractors shall thoroughly examine the site within the project scope for conditions that may affect their pricing. The price proposal shall be firm and final, no adjustments shall be granted if contractors fail to account for site variances.

Request for clarifications from Contractors must be submitted in writing no later than **5:00 p.m., on February 15, 2021.** All procurement questions related to this solicitation shall be directed to Yu (Judy) Zhu, Purchasing Manager via email to yu.zhu@montgomerycollege.edu. All technical questions shall be directed to Yuling Mei, RA, LEED AP, Senior Architect, via email to yuling.mei@montgomerycollege.edu.

Only answers provided via a written addendum issued by the College will be binding.

Proposals will be evaluated by a College Selection Committee. Evaluation will be based on the substantiated ability of the Contractor to perform the required construction services described in the Request for Proposal documents, and the Contractor's responsiveness to Technical Proposal and Price Proposal requirements. Technical Proposals will be opened first and reviewed. Price Proposals from only those Contractors deemed qualified following the review of the Technical Proposals, will then be opened and reviewed. Price Proposals from those Contractors deemed not qualified by the College after the review of the Technical Proposals will not be opened. An award will be made in the best interest of the College to the most responsive and responsible qualified Contractor with the **lowest Base Price Total** that can meet or exceed the terms, conditions, and specifications of this solicitation.

Bid and Performance Security Requirements apply as follows: **If a Contractor's total bid amount exceeds \$100,000, a Bid Bond in an amount not less than 5% of the total bid amount, including all add alternates, but excluding all deduct alternates is required for bidding. The successful Contractor will be required to provide 100% Performance and Labor and Material Payment Bonds, insurance certificate and other required documents after the contract award, and prior to start of any work.**

State of Maryland prevailing wage rate requirements and reporting procedures, State apprenticeship and training fund law do not apply to this project.

MINORITY VENDORS ARE ENCOURAGED TO RESPOND TO THIS SOLICITATION.

IMPORTANT: YOUR PROPOSAL WILL BE JEOPARDIZED IF ANY PORTION OF THIS INQUIRY IS NOT COMPLETE. NO PROPOSAL WILL BE ACCEPTED AFTER THE DATE AND TIME STATED ABOVE.



Patrick L. Johnson, MBA
Director of Procurement

NOTE: Prospective Offerors who have received this document from a source other than the Procurement Office should immediately contact the Procurement Office and provide their name and e-mail address so that amendments to the Bid/RFP or other communications can be sent to them. Failure to contact the Procurement Office may result in non-receipt of important information.

REGISTRATION OF CORPORATIONS NOT REGISTERED IN THE STATE OF MARYLAND Pursuant to 7-202 et. Seq. of the Corporation and Associations Article of the Annotated Code of Maryland, corporations not incorporated in the State of Maryland shall be registered with the State Department of Assessments and Taxation, 301 West Preston Street, Baltimore, Maryland 21201 before doing any interstate or foreign business in this State. A copy of the registration or application for registration may be requested by the College.

CONDITIONS AND INSTRUCTIONS

- 1. ADDITIONAL ORDERS:** Unless it is specifically stated to the contrary in the bid response, the College reserves the option to place additional orders against a contract awarded as a result of this solicitation at the same terms and conditions, if it is mutually agreeable.
- 2. APPLICABLE LAW:** This contract shall be construed and interpreted according to Maryland law.
- 3. ASSURANCE OF NON-CONVICTION OF BRIBERY:** The bidder hereby declares and affirms that, to its best knowledge, none of its officers, directors or partners and none of its employees directly involved in obtaining contracts has been convicted of bribery, attempted bribery or conspiracy to bribe under the laws of any state or the Federal government.
- 4. AUDIT:** Bidder shall permit audit and fiscal and programmatic monitoring of the work performed under any contract issued from this solicitation. The College shall have access to and the right to examine and/or audit any records, books, documents and papers of bidder and any subcontractor involving transactions related to this Agreement during the term of this Agreement and for a period of three (3) years after final payment under this Agreement.
- 5. AWARD CONSIDERATIONS:** Awards of this bid will be made to the lowest responsible bidder conforming to specifications with consideration being given to quantities involved, time required for delivery, purpose for which required, responsibility of bidder and its ability to perform satisfactorily with consideration to any previous performance for Montgomery Community College. A bid may be awarded at the sole discretion of the College in the best interest of the College. Prompt payment discounts will not be considered in bid evaluation. All discounts other than prompt payment are to be included in bid price.
- 6. BID AND PERFORMANCE SECURITY:** If bid security is required, a bid bond or cashier's check in the amount indicated on the bid cover must accompany each bid and be made payable to Montgomery Community College. Corporate or certified checks are not acceptable. Bonds must be in a form satisfactory to the College and underwritten by a company licensed to issue bonds in the State of Maryland. If bid security fails to accompany the bid, it shall be deemed unresponsive, unless the Director of Procurement deems the failure to be nonsubstantial. Such bid bonds or checks will be returned to all except the three (3) lowest bidders within five (5) days after the opening of bids, and the remaining checks or bid bonds will be returned to all but successful bidder(s) within forty-eight (48) hours after award of contract. If a performance bond is required, the successful bidder must submit an acceptable performance bond in the designated amount of the bid award, prior to award of contract. All bid bonds will be returned to the successful bidder(s) within fortyeight (48) hours after receipt of the performance bond.
- 7. BRAND NAMES:** Brand name materials used in these specifications are known and acceptable. Bids including proposals to use alternate brands are invited as long as they are of equal type and equal or better quality. The burden of proof that alternate brands are in fact equal or better falls on the bidder, and proof must be to the College's satisfaction.
- 8. COMPLIANCE WITH LAWS:** Bidder agrees to comply, at no additional expense, with all applicable Executive orders, Federal, State, bi-county, regional and local laws, ordinances, rules and regulations in effect as of the date of this Agreement and as they may be amended from time to time, including but not limited to the equal employment opportunity clause set forth in 41 CFR 60-250.4.
- 9. CONTINGENT FEES:** Bidder hereby declares and affirms that neither it nor any of its representatives has employed or retained any person, partnership, corporation, or other entity, other than a bona fide employee or agent working for the bidder, to solicit or secure a contract, and that it has not paid or agreed to pay any person, partnership, corporation, or other entity, other than a bona fide employee or agent, any fee or any other consideration contingent on the making of a contract as a result of this solicitation.
- 10. DELIVERY AND PACKING:** All prices quoted must include delivery. All goods delivered under this contract shall be packed in accordance with accepted trade practices. No charges may be made over and above the bid price for packaging, or for deposits or containers unless specified in the bid. No charge will be allowed for cartage unless by prior written agreement. Complete deliveries must be made by the successful bidder to the designated location as indicated on the Montgomery Community College purchase order. A packing slip shall be included in each shipment. All deliveries must be prepaid and must be delivered to each location designated on purchase order at no additional cost. DELIVERIES MUST BE MADE TO THE SPECIFIED LOCATION. NO COLLECT SHIPMENTS OR SIDEWALK DELIVERIES WILL BE ACCEPTED.
- 11. DELIVERY OF BIDS:** Sealed bids must be received in the Procurement Office by the date and time specified in the bid in order to be considered. NO LATE BIDS OR PROPOSALS WILL BE ACCEPTED. Late bids will be returned to the bidder unopened. Bids submitted by mail must be addressed to the Procurement Office, Montgomery College, P.O. Box 1006, Rockville, Maryland 20850, and clearly marked to indicate the bid number, title and opening date. Hand delivered bids will be accepted only at the Procurement Office, Montgomery College Central Administrative Center, located at 9221 Corporate Boulevard, Rockville, Maryland 20850.
- 12. DISPUTES:** Any dispute arising under a contract awarded as a result of this bid which is not disposed of by agreement shall be decided by the President of the College or designee. Pending the final decision of the dispute, contractor shall proceed with the contract performance. Nothing hereunder shall be interpreted to preclude the parties from seeking after completion of the contract any and all remedies provided by law.
- 13. ERRORS IN BIDS:** Bidders are assumed to be informed regarding conditions, requirements, and specifications prior to submitting bids. Failure to do so will be at the bidder's risk. Bids already submitted may be withdrawn without penalty prior to bid opening. Errors discovered after bid opening may not be corrected. In the case of an error in price extension, the unit price will govern. The intention of the bidder must be evident on the face of the bid.
- 14. HAZARDOUS AND TOXIC SUBSTANCES:** Bidder must comply with all applicable Federal, State, County and bi-county laws, ordinances and regulations relating to hazardous and toxic substances, including such laws, ordinances and regulations pertaining to access to information about hazardous and toxic substances, and as amended from time to time. Bidder shall provide the College with a "Material Safety Data Sheet" or in the case of a controlled hazardous waste substance, a hazardous waste manifest for all hazardous chemicals listed or subsequently added to the Chemical Information List in compliance with applicable laws, ordinances and regulations.
- 15. INSPECTION OF PREMISES:** If a site visit is recommended or required, each bidder is responsible to visit the site(s) prior to submitting a bid in order to observe the existing conditions affecting the work, and to obtain precise dimensions of the area(s) involved. No allowance will be made to the successful bidder, at a later date, for additional work required because of his or her failure to visit the site and/or to obtain the exact dimensions. Discrepancies, if any, must be reported to the College.
- 16. INSURANCE:** If a contract results from this bid, the contractor shall maintain such insurance as will indemnify and hold harmless the College from Workmen's Compensation and Public Liability claims for property damage and personal injury, including death, which may arise from the contractor's operations under this contract, or by anyone directly or indirectly employed by him/her.
- 17. MARYLAND PUBLIC INFORMATION ACT:** Bidder recognizes that the College is subject to the Maryland Public Information Act, Title 10 of the State Government Article of the Annotated Code of Maryland. Bidder agrees that it will provide any justification as to why any material, in whole or in part, is deemed to be confidential, proprietary information or trade secrets and provide any justification of why such materials should not be disclosed pursuant to the Maryland Public Information Act.
- 18. NON-ASSIGNMENT AND SUBCONTRACTING:** Bidder shall not assign any contract or any rights or obligations hereunder without obtaining prior written consent of the College. No contract shall be made by bidder with any other party for furnishing the services to be performed under a contract issued from this solicitation without the written approval of the College. These provisions will not be taken as requiring the approval of the contract of employment between bidder and its personnel.
- 19. NON-COLLUSION:** Bidder certifies that it has neither agreed, conspired, connived, or colluded to produce a deceptive show of competition in the compilation of the bid or offer being submitted herewith; bidder also certifies that it has not in any manner, directly or indirectly, entered into any agreement, participated in any collusion to fix the bid price or price proposal of the bidder or offeror herein or any competitor, or otherwise taken any action in restraint of free competitive bidding in connection with the contract for which the within bid or offer is submitted.
- 20. NON-DISCRIMINATION:** Bidder assures the College that, in accordance with applicable law, it does not, and agrees that it will not discriminate in any manner on the basis of sex, race, age, color, creed, national origin, religious belief, handicap, marital status, or status as a disabled veteran or veteran of the Vietnam era. Bidder further agrees to post in conspicuous places notices setting forth the provisions of the nondiscrimination clause and to take affirmative action to implement the provisions of this section. Bidder further assures the College that, in accordance with the Immigration Reform and Control Act of 1986, it does not and will not discriminate against an individual with respect to hiring, or recruitment or referral for a fee, of the individual for employment or the discharging of the individual from employment because of such individual's national origin or in the case of a citizen or intending citizen, because of such individual's citizenship status.
- 21. PATENTS:** Bidder guarantees that the sale and/or use of the goods offered will not infringe upon any U.S. or foreign patent. Bidder will at his/her own expense, indemnify, protect and save harmless the College, its trustees, employees, agents and students with respect to any claim, action, cost or judgment for patent infringement, arising out of the purchase or use of these goods.
- 22. PREPARATION OF BID:** Bids submitted must be hand signed by an authorized agent of the company submitting the bid. Notification of award will be made by "Notice of Intent to Award" and/or purchase order. A bidder may attach a letter of explanation to the bid for clarification. Bidders will be required, if requested by Montgomery Community College, to furnish satisfactory evidence that they are, in fact, bona fide manufacturers of or dealers in the items listed, and have a regularly established place of business. The College reserves the right to inspect any bidder's place of business prior to award of contract to determine bidder responsibility.
- 23. PRODUCT TESTING DURING TERM OF CONTRACT:** Goods delivered under any contract resulting from this Request for Bid may be tested for compliance with specifications stipulated herein. Any shipment failing to meet or comply fully with the specification requirements will be rejected. The cost of testing a representative sample of an order or shipment for acceptance shall be borne by the College unless the order is rejected for failure to meet specifications or purchase description. In such cases of rejection, the cost of testing will be charged back to the vendor.
- 24. RECORD RETENTION:** If awarded a contract, vendor shall maintain books and records relating to the subject matter of this Agreement, including but not limited to all charges to the College, for a period of three (3) years from the date of final payment under this Agreement.
- 25. REJECTIONS AND CANCELLATIONS:** Montgomery Community College reserves the right to accept or reject any or all bids in whole or in part for any reason. The College reserves the right to waive any informalities and to make awards in the best interest of the College. The College also reserves the right to reject the bid of any bidder who has previously failed to perform adequately on a prior award for furnishing goods and/or services similar in nature to those requested in this bid. The College may cancel this solicitation in whole or in part, in its sole discretion.
- 26. RIDER PROVISION FOR MONTGOMERY COUNTY PUBLIC SCHOOLS AND MONTGOMERY COUNTY:** The bidder agrees when submitting the bid that it will make available to every office and department of the Montgomery County Public Schools and the Montgomery County Government the same bid prices, terms and conditions offered during the term of contract. Orders will be placed directly by these agencies. There will be no penalty if bidder notes exception to this provision in the bid offered.
- 27. SAMPLES AND CATALOG CUTS:** If samples are required, bidder shall be responsible for delivery of samples to location indicated. All sample packages shall be marked "Sample for Procurement Office, Bid No. ____" and each sample shall be tagged or marked. Failure of the bidder to clearly identify samples as indicated may result in rejection of bid. The College reserves the right to test any materials, equipment or supplies delivered to determine if the specifications have been met. Samples will not be returned.
- 28. SIGNATURE:** Each bid must show the full business address and telephone number of the bidder and be signed by the person or persons legally authorized to sign such contracts. All correspondence concerning the bid and contract, including the bid summary, copy of contract, and purchase order, will be mailed or delivered to the address shown on the bid. NO BID WILL BE ACCEPTED WITHOUT ORIGINAL SIGNATURE.
- 29. TAXES:** The College is exempt from Federal and Maryland taxes. Exemption Certificates are available upon request. Bidder shall be responsible for the payment of any and all applicable taxes resulting from any award and/or any activities hereunder, including but not limited to any applicable amusement and/or sales taxes.
- 30. TERMINATION BASED ON LACK OF FUNDING:** Any contract awarded as a result of this solicitation will be subject to funding and continued appropriation of sufficient funds for the contract. For purposes of this solicitation, the College's appropriating authority is deemed to be the Board of Trustees of Montgomery Community College. Insufficient funds shall be grounds for immediate termination of this solicitation.
- 31. TERMINATION FOR DEFAULT:** If an award results from this bid, and the contractor has not performed or has unsatisfactorily performed the contract, payment shall be withheld at the discretion of the College. Failure on the part of the contractor to fulfill contractual obligations shall be considered just cause for termination of the contract and the contractor is not entitled to recover any costs incurred by the contractor up to the date of termination.
- 32. TERMINATION FOR THE CONVENIENCE OF THE COLLEGE:** The performance of the work or services under a contract as a result of this solicitation may be terminated in whole or in part, whenever the President of Montgomery Community College shall deem that termination is in the best interest of the College. Such determination shall be in the sole discretion of the President. In such event, the College shall be liable only for payment in accordance with the payment provisions of the contract for work or services performed or furnished prior to the effective date of termination. Termination hereunder shall become effective by delivery to contractor of written notice of termination upon which date the termination shall become effective.
- 33. WARRANTY:** Bidder expressly warrants that all articles, material and work offered shall conform to each and every specification, drawing, sample or other description which is furnished to or adopted by the College and that they will be fit and sufficient for the purpose intended, merchantable, of good material and workmanship, and free from defect. Such warranty shall survive a contract and shall not be deemed waived either by the College's acceptance of said materials or goods, in whole or in part, or by payment for them, in whole or in part. The bidder further warrants all articles, material and work performed for a period of one year, unless otherwise stated, from date of acceptance of the items delivered and installed, or work completed. All repairs, replacements or adjustments during the warranty period shall be at bidder's sole expense.

INSTRUCTIONS TO CONTRACTORS

PART 1 - RFP AND AWARD SCHEDULE

1.1 REQUEST FOR PROPOSAL SCHEDULE

It is the College's intent to administer the Request for Proposal process for this project according to the schedule dates outlined below. The College reserves the right to alter schedule dates as may be determined necessary in the College's best interests.

January 29, 2021 RFP Documents Available

February 15, 2021 Last Date for Requests for Information

February 22, 2021 Technical Proposal (Part A) and Price Proposal (Part B) Due

March 15, 2021 Proposal Evaluation Process Concludes and Recommendation for Contract Award

1.2 AWARD SCHEDULE

It is the College's intention to make an award to the most responsive, and responsible qualified Contractor with the lowest Base Price Total that can meet or exceed the terms, conditions, and specifications of the solicitation, in accordance with the College policy and procedures.

Notice to proceed will be timely provided upon receipt of documentation and information required from the Contractor before the start of work including, but not limited to, performance, payment, labor and material payment bonds and Insurance certificates.

Notwithstanding these expectations, the College may require additional time to administer the contract award or other processes. To accommodate for this possibility, prices must remain firm for one hundred twenty (120) days from price proposal due date. Anticipated Contract Award date, Notice to Proceed date and project scheduling expectations may be adjusted in concert with this provision. It is the Contractor's sole responsibility to ensure their price proposal response accommodates this requirement.

PART 2 - PRE-PROPOSAL CONFERENCE

2.1 No Pre-Proposal Conference will be held.

PART 3 - RFP DOCUMENTS

3.1 RFP documents include the Invitation Letter of RFP, Instructions to Contractors, Supplementary Instructions to Contractors, Required Submissions, Information Available to Contractors, Technical Proposal Form (Part A) and attachments thereto, Price Proposal Form (Part B) and attachments thereto, Bid Bond, Verification of Examination of Site Conditions, Contractor's Qualification Statement, Subcontractor Information Form, Minority Participation Form, Procurement Office Questionnaire, Conflict of Interest Statement, Montgomery College Standard Performance Bond, Labor and Material Payment Bonds, Application and Certificate for Payment, Montgomery College General Conditions of the Contract, Montgomery College Supplementary Conditions of the Contract, Specifications, Drawings and all Addenda if applicable.

- 3.2 An electronic PDF of the RFP documents can be downloaded from the College Procurement website at <http://www.montgomerycollege.edu/procure/> at no charge.
- 3.3 Montgomery College is not responsible for content of and/or information obtained from sources not listed in the RFP. Only information obtained through the College's Procurement office, on its website or from sources listed in the RFP should be considered reliable. It is highly recommended that Contractors obtain all information pertaining to this RFP from the College's Procurement Web site at <http://www.montgomerycollege.edu/procure/> and those sources referred to in the RFP document. It is the Contractor's responsibility to assure that accurate information has been used in preparation of their proposal response.

PART 4 - SITE EXAMINATION

- 4.1 A site examination opportunity will be provided at the project site **at 11:00 a.m. on February 10, 2021**. Due to the ongoing COVID-19 pandemic and College restrictions to access to the campuses, Contractors planned to attend the site visit shall email Ms. Yuling Mei, RA, LEED AP at yuling.mei@montgomerycollege.edu in advance, advising the number of people to attend the site visit. Contractors shall follow College protocols for visiting the campus available at <https://www.montgomerycollege.edu/coronavirus/health-and-safety/return-to-campus-guidelines.html>. Persons coming on campus should assess their own health before arriving. A self-assessment checklist is available at <https://www.montgomerycollege.edu/coronavirus/covid-assessment-visitors.html>. The College Public Safety officer may ask this information before allowing the Contractors at the entry of the building. Contractors can show the confirmation email as evidence of self-assessment.

Besides the College's requirements, the Montgomery County requires all persons, whether indoors or out, to wear a mask within six (6) feet of one another.

- 4.2 Potential Contractors shall thoroughly examine and investigate existing site conditions that may affect their pricing proposal, prior to proposal submission. Site examination is mandatory and verification of the examination by a College representative is required. The price proposal shall be firm and final, no adjustments shall be granted at a later date, if contractors fail to account for site variances.
- 4.3 Contractors **MUST** attach the Verification of Examination of Site Conditions form, which is included in Section 004400 and is to be signed by an authorized College Representative upon the completion of site examination, and include it in the Technical Proposal (Part A) submission.
- 4.4 Proposal submission shall serve as verification that, at the time of receipt of the proposal, the Contractor has inspected the site and has read and is thoroughly familiar with the RFP documents (including all Addenda); has examined and finds the Specifications and the Drawings adequate; and agrees that given what the Specifications and Drawings require, in any part of the Work, the required result can be produced. Failure or omission of a Contractor to inspect the site or to examine any form, instrument or document shall in no way relieve a Contractor from obligations with respect to their Proposal.
- 4.5 Data in the RFP documents pertaining to existing conditions is for convenience only and does not supplant obtaining first-hand information at the site. Submission of proposals shall constitute acceptance by the Contractor of existing site conditions as a part of the requirements for this work.

PART 5 - INTERPRETATION OR CORRECTION OF RFP DOCUMENTS

- 5.1 The RFP documents should be examined carefully. Should any Contractors find discrepancies or omissions in the solicitation documents, or be in doubt as to the meaning of any item(s), Request for Clarification related to procurement shall be submitted to Yu (Judy) Zhu, Purchasing Manager, via email to yu.zhu@montgomerycollege.edu. All technical questions shall be directed to Yuling Mei, RA, LEED AP, Senior Architect via email to yuling.mei@montgomerycollege.edu.
- 5.2 Contractors shall be responsible for reviewing and coordinating the submission of clarifications requested by Subcontractors or Vendors. Clarification requests made directly by Subcontractors or Vendors will not be accepted by the College.
- 5.3 **REQUESTS FOR CLARIFICATIONS MUST BE SUBMITTED BY EMAIL NO LATER THAN 5:00 PM ON FEBRUARY 15, 2021.**
- 5.4 No oral interpretation of the meaning of the RFP documents will be made to any Contractor, and oral responses or oral interpretations will not be binding in any way to modify or change any requirement in the RFP documents.
- 5.5 The College will review the written questions and requests for clarification, if any, and any and all such interpretations and any supplemental instructions will be issued in the form of written Addenda to the RFP. Any issued Addenda may be obtained by downloading the file from the College's Procurement website <http://www.montgomerycollege.edu/procure> at no charge.
- 5.6 All Addenda shall become part of the RFP documents.
- 5.7 Notification regarding addenda posted at the above referenced website will be provided by e-mail, to all Contractors who are known by the College to have received a complete set of Proposal Documents by downloading the RFP from the College's Procurement website and who have provided an accurate current e-mail address. To ensure that an accurate notification attempt can be made, and is delivered to the appropriate contact person, the College requests the Contractor register one person's contact information with the College's website. The College will make a good faith, one-time, attempt to e-mail the notification to that contact person, but cannot be held responsible for unsuccessful delivery in the event that an incorrect e-mail address is provided and/or technical difficulties are experienced in the transmission.
- 5.8 It is the Contractor's sole responsibility to ensure receipt of all Addenda. It is highly recommended that the Contractor check the College's website for all posted Addenda prior to submitting their proposals. All Addenda shall become part of the Request Proposal documents.
- 5.9 Failure of any Contractor to receive any such Addenda or interpretation shall not relieve the Contractor from any obligation or requirement provided for in the Addenda or issued interpretation.

PART 6 - PREPARATION AND SUBMITTAL OF PROPOSALS (NEW)

- 6.1 A submittal consisting of the Technical Proposal, and the Price Proposal are required when responding to this Request for Proposal.
- 6.2 All proposals must be submitted electronically, in two separate PDF file attachments. One attachment shall consist of the Technical Proposal, and second attachment shall consist the Price Proposal. Both attachments shall be sent together, in a single email to vendor.proposals@montgomerycollege.edu, prior to the RFP closing date and time as outlined in

RFP. Subject line of email must include the following: Offeror's Response to RFP No. E621-004, Physical Education Building Pool Stair 4 Repair, Rockville Campus.

- 6.3 Electronic proposal submittal is based on Eastern Standard Time (EST). **Any proposal received at the above email address, after the EST submittal deadline, will be automatically rejected. Proposals sent to other email address other than the above specified will NOT be accepted.**
- 6.4 In addition to the electronic submission, one original hardcopy of Technical Proposal and Price Proposal shall be mailed/delivered to the address below. **Hard copy proposal must be received by the College no later than ten (10) business days after the RFP due date and prior to the contract award.**

Montgomery College
Central Receiving Office
Attn.: Office of Procurement
7602 Standish Place
Derwood, Maryland 20855

The College Central Receiving Office is currently operating from 10:00 a.m. to 2:00 p.m., Monday through Friday, except for College Holidays. A copy of College academic calendar is available at: <https://www.montgomerycollege.edu/academics/academic-calendar.html>). Contact: James Fowlkes, Central Receiving Supervisor. Cell Phone: (240) 620-2640.

- 6.5 Technical Proposals must be submitted on the enclosed Technical Proposal Form and must include all the attachments listed on the Technical Proposal Form. Price Proposals must be submitted on the enclosed Price Proposal Form and must include all the attachments listed on the Price Proposal Form. Proposals must be signed by an authorized officer of the firm. Blank spaces must be filled in, either in ink or typewritten, both in words and figures. The person signing the Proposals must initial all erasures on or changes to the forms.
- 6.6 The hardcopy of Technical Proposals and Price Proposals must each be submitted in separately sealed envelope or box. Contractors must copy and paste the following proposal envelope sample labels on the outside of their envelopes for each proposal submitted. It is mandatory that the proposal envelope labels are used or this exact information is provided on the envelopes of the sealed proposal. Failure to do so may cause the proposal to be rejected.

PROPOSAL ENVELOPE LABEL

PART A - TECHNICAL PROPOSAL

RFP No.:	E621-004 (A)
Proposal Due Date:	February 22, 2021
Proposal Due Time:	2:00 PM
Contractor's Name:	_____
Contractor's Address:	_____ _____
Project Title:	Physical Education Building Pool Stair 4 Repair Rockville Campus

PART B - PRICE PROPOSAL

RFP No.: E621-004 (B)
Proposal Due Date: **February 22, 2021**
Proposal Due Time: 2:00 PM
Contractor's Name: _____
Contractor's Address: _____
Project Title: Physical Education Building Pool Stair 4 Repair
Rockville Campus

- 6.7 Proposals shall be certified, signed, and dated by a bona fide agent of the Offeror and include minority classification if applicable. Failure to include all required submittals may render the proposal non-responsive. The College will reject any Offeror without an authorized signature.

PART 7 - DELAYED OPENING

- 7.1 No proposal will be accepted after the stated date and time. In the event the College is closed on the RFP closing date due to an unforeseen circumstance, the RFP will close at the stated time on the next open business day, unless the Contractor is notified otherwise.

PART 8 - ERRORS IN PROPOSALS

- 8.1 With the submission of this proposal, Contractors assure the College that they are fully informed regarding conditions and requirements of the project site and the proposal documents prior to submitting proposals. Contractors are responsible for seeking proper information and making the necessary investigations. Failure to do so is at the Contractor's sole risk.

PART 9 - WITHDRAWAL OF PROPOSALS

- 9.1 Contractor may not withdraw or modify the Price Proposal for one hundred and twenty (120) calendar days after the Price Proposal due date and time.
- 9.2 The College may require additional time to administer College, County and/or State contract award or other regulatory processes. To accommodate for this possibility, prices must remain firm for one hundred twenty (120) days from the price proposal due date. Anticipated Contract Award date, Notice to Proceed date and project scheduling expectations may be adjusted in concert with this provision. It is the Contractor's sole responsibility to ensure that their price proposal response accommodates this requirement.

PART 10 - EVALUATION OF PROPOSALS

- 10.1 The contract will be awarded in consideration of Technical Proposal and Price Proposal and the substantiated ability of the low responsible and responsive Contractor under an equitable bid process to perform the required construction services described in the RFP Documents.
- 10.2 Evaluation Criteria
- 10.2.1 Technical Proposal (Part A):

Part A Technical Proposal responses will be opened first, and evaluated by a College Evaluation Committee based on the substantiated ability of the Contractor to perform the required construction services described in the RFP documents, and the Contractor's

responsiveness to the Technical Proposal requirements **on a "go," "no-go" basis only**. Price Proposals from only those Contractors who are deemed qualified following the review of the Technical Proposals, will then be opened and reviewed. Price Proposals from those Contractors deemed not qualified after the review of the Technical Proposals will not be opened.

Part A Contractor's Technical Proposal will be evaluated based on the following key areas:

- a. Contractor Qualification Statement including Financial Statements
- b. Relevant Project Experience
- c. Professional Qualifications and Technical Competence of Proposed Project Team
- d. Quality Control Program
- e. Proposed Project Schedule Outline

10.2.2 Price Proposal (Part B):

Price Proposals from only those Contractors who are deemed qualified following the review of the Technical Proposals, will then be opened and reviewed for responsiveness. In order to be considered for the award, Contractor must bid all items in the Price Proposal Form and fill out all blanks. Failure to do so may deem a Contractor non-responsive. Contractor's Price Proposal will be evaluated based on the following:

- a. Base Price Total
- b. Submission of an acceptable Bid Bond (required if the total bid amount exceeding \$100,000)
- c. Bonding Company Letter Guaranteeing the Required 100% Performance, Labor and Material Payment Bonds

10.3 An award will be recommended in the best interest of the College to **the most responsive, and responsible qualified Contractor with the lowest Base Price Total** that can meet or exceed the terms, conditions, and specifications of the solicitation.

PART 11 – COLLEGE'S RIGHTS

11.1 The College reserves the following rights to be exercised at the College's sole discretion:

- A. To make such investigation as deemed necessary to determine the qualifications of the Contractor and to determine the ability of the Contractor to perform the work. The Contractor shall furnish to the College all such information and data as the College may request. The College reserves the right to reject any proposal if the evidence submitted by, or investigation of, such Contractor fails to satisfy the College that such Contractor is properly qualified to carry out the obligations of the contract and to complete the work contemplated herein.
- B. Conditional proposals will not be accepted.
- C. To reject any or all proposals and to make awards in the best interest of the College, in the name of the Board of Trustees. The College also reserves the right to cancel the RFP.
- D. To accept or reject any item of price proposal or any alternate prices in the priority order established by the Price Proposal Form.

- E. To consider informal, any proposal not prepared or submitted in accordance with the provisions hereof. The College may at its sole discretion waive any informality. A waiver of any provision of the Proposal Documents shall not constitute a waiver of any subsequent breach.
 - F. To defer award of the contract for a period of up to one hundred and twenty (120) calendar days after receipt of the proposals. Anticipated Contract Award date, Notice to Proceed date and project scheduling expectations may be adjusted in concert with this provision. It is the Contractor's sole responsibility to ensure their Price Proposal response accommodates this requirement. Upon Award, prices must remain firm for the duration of the contract.
 - G. If no award or other disposition is made, the expiration of the one hundred and twenty (120) calendar days will constitute rejection of all price proposals without any further action by the College.
 - H. The Contractor deemed most responsible and responsive with the lowest Base Price Total under an equitable bid process will be recommended for contract award to the College's Board of Trustees.
- 11.2 The award will be made subject to the availability of public funds and only if it is in the best interest of the College to award the project. The College reserves the above rights to be exercised at the College's sole discretion.

PART 12 - AWARD CONSIDERATIONS

- 12.1 An award will be recommended in the best interest of the College to the **most responsive and responsible qualified contractor with the lowest Base Price Total** that can meet or exceed the terms, conditions, and specifications of this solicitation, including project delivery requirements. Only alternates submitted by the recommended Contractor may be reviewed and considered by the College. The College reserves the right to accept or reject any alternate pricing.

PART 13 - REGISTRATION OF CORPORATIONS NOT REGISTERED IN THE STATE OF MARYLAND

- 13.1 Pursuant to 7-202 et. Seq. of the Corporation and Associations Article of the Annotated Code of Maryland, corporations not incorporated in the State of Maryland shall be registered with the State Department of Assessments and Taxation, 301 West Preston Street, Baltimore, Maryland 21201 before doing any interstate or foreign business in this State. A copy of the registration or application for registration may be requested by the College.

END OF INSTRUCTIONS TO CONTRACTORS

SUPPLEMENTARY INSTRUCTIONS TO CONTRACTORS

PART 1 – PRELIMINARY PROJECT SCHEDULE

- 1.1 Preliminary schedule instructions apply to the project as follows:
 - A. The College offers classes during traditional Fall and Spring academic semesters, as well as during a winter intersession and two summer session periods. Contractor is reminded that they may be asked to refrain from noisy work during the associated testing periods when tests are scheduled in adjoining buildings. Specific calendars and constraints will be provided by the College when available. Calendars are subject to adjustment in the event that inclement weather, or other cause, closes the College.
 - B. Due to the ongoing COVID-19 pandemic, the College is open remotely. Most 2021 spring semester classes will be fully online. Students in certain programs may come to campus for some hybrid classes. Access to the College campuses is restricted.

PART 2 – PREVAILING WAGES

- 2.1 With regard to General Condition 3.3.1.3, please note that this project is NOT subject to State of Maryland DLLR Prevailing Wage Rate requirements.

PART 3 – MINORITY PARTICIPATION

- 3.1 Pursuant to Board Resolutions #87-82 and #87-83, adopted on July 20, 1987, it is the policy of Montgomery College to encourage minority businesses to provide goods and services for the performance of College functions. Minority businesses include non-profit entities organized to promote the interests of handicapped persons, and firms that are 51% owned and controlled by a member(s) of socially or economically disadvantaged minority group, which includes: African American, American Indian/Native American, Asian, Hispanic, women, and physically or mentally disabled.
- 3.2 The Contractor must submit an updated College's Minority Participation Form and include in the Technical Proposal submission.
- 3.3 If the Contractor is not a minority business entity, the Contractor is encouraged to develop a plan that, at a minimum, will award 15% of the total contract value to subcontractors and/or vendors that are minority businesses.
- 3.4 Non-minority Contractors are advised that following contract award, within three business days of request by the College, the Contractor shall provide a list indicating minority subcontractor and/or vendor participation anticipated for the project. The Contractor shall provide the College with routine updates should any changes in subcontractor or vendor status occur during the contract term.

PART 4 – BONDS

- 4.1 If Contractor's total bid amount exceeds \$100,000.00, Contractor is required to furnish a Bid Bond and a Letter of Intent from its Bonding Company for Physical Education Building Pool Stair 4 Repair, Rockville Campus with the Price Proposal (Part B), as required below.

- 4.1.1 Contractor shall submit a photocopy of the Bid Bond in the electronic Price Proposal submission and one original Bid Bond in the hardcopy submission. The Bid Bond must be from a surety company authorized to do business in the State of Maryland, acceptable to the College, made payable without condition to the College, for not less than 5% of the total base bid amount, including all bid alternates, but excluding all deduct alternates, or a cashier's check in the amount of not less than 5% of the total base bid amount, including all bid alternates, but excluding all deduct alternates. Bid Bond shall be prepared and submitted on AIA Form A310-2010, "BID BOND".
- 4.1.2 Contractor shall submit one original letter from the Contractor's bonding company stating that it guarantees to furnish the required 100% performance and labor and material payment bonds if the Contractor is recommended for contract award. Letter provided shall not be generic, but must be written specifically for this project.
- 4.2 Prior to the execution of this Contract, the College may require the Contractor to furnish a performance bond, properly executed on the Montgomery College Standard Performance Bond, a copy of which is included in the Request for Proposal documents, and a labor and material payment bond executed on AIA Document A312-2010, "PAYMENT BOND", for 100% of the amount of the Contract.
- 4.3 Upon failure or refusal to execute and deliver the Contract and bonds required within five (5) days (Saturdays, Sundays and legal holidays excluded) after having received notice of acceptance of its proposal, the Contractor shall forfeit to the College, as liquidated damages for such failure or refusal, the bid security included with its proposal.
- 4.4 After the College and the successful Contractor have executed a contract, or if no contract has been executed within ninety (90) calendar days after the proposal due date, and Contractor has not been notified of acceptance of its proposal, Contractor may request return of his Bid Bond.
- 4.5 If at any time, the bonding Company becomes insolvent, files for bankruptcy or for any reason whatsoever loses its right to do business in the state of Maryland, the Contractor shall, within ten (10) calendar days after notice from the College to do so, substitute an acceptable Bond (or bonds) in such form and sum and signed by such other Bonding Company as may be satisfactory to the College.
- 4.6 Attorneys-in-fact who sign bid bonds or contract bonds must file with each bond, a certified and effectively dated copy of their power of attorney.

PART 5 – INSURANCE

- 5.1 Prior to start of any work, the successful Contractor must provide sufficient evidence of insurance showing adequate coverage as defined in the Request of Proposal documents.

PART 6 – FORM OF CONTRACT

- 6.1 The Contract Agreement between the successful Contractor and the College for the Physical Education Building Pool Stair 4 Repair, Rockville Campus project will be executed on the College standard Purchase Order.

- 6.2 The Contract Documents are the purchase order, the Request for Proposal in its entirety, any Addenda issued prior to execution of the Contract, Modifications after execution of the Contract, the Performance Bond, the Labor and Materials Payment Bond, and the Contractor's proposal accepted by the College. The term "Contract" used in the Specifications or Drawings shall be considered as synonymous with the term "Contract Documents."
- 6.3 Any exceptions to the Montgomery College General Conditions of the Contract or any other deviations to the RFP requirements must be included in the Technical Proposal (Part A) submission to initiate further consideration by the College. An exception to the Montgomery College General Conditions of the Contract or any other deviations to the RFP requirements by the Contractor are considered by the College to be the request for information.
- 6.4 The College makes no implicit or explicit statement as to any willingness to deviate from all requirements set forth in the Request for Proposal documents.
- 6.5 Unless explicitly stated by the Contractor in the Proposal submission that an exception to the Montgomery College General Conditions of the Contract or any deviation to the RFP requirements are a condition of the proposal, the College does not consider such exceptions provided by the Contractor to be the submission of a conditional proposal.

PART 7 – LIST OF SUBCONTRACTORS (UPON REQUEST)

- 7.1 Within 3 business days from request by the College, Contractor shall provide names, addresses, Maryland registration/license number, and indication of minority status (if applicable), for all the Subcontractors proposed to be retained by the Contractor for this project, regardless of anticipated contract value.

PART 8 – VENDOR QUALIFICATIONS (UPON REQUEST)

- 8.1 The College's intent with regard to verification of Vendor qualifications, and financial stability is that it is the Contractor's responsibility to evaluate the qualifications, financial viability and solvency of all vendors used for the project.
- 8.2 Within 3 business days from the request by the College, Contractor shall submit to the College a Qualification Statement for each Principal Vendor, herein defined as those Vendors whose contract value is anticipated to exceed \$ 100,000, to include the following:
- a) Name
 - b) Address
 - c) Type of Work Performed
 - d) Years in Business
 - e) Representative Project List (including at least three projects of similar size, scope and complexity)
 - f) References (list at least three references, including contact name and telephone number)
 - g) Copy of Maryland registration/license number, if applicable
- 8.3 The College reserves the right to reject any Vendor.

PART 9 – TAXES

- 9.1 In the event of a conflict between General Conditions and any other provision in the Request for Proposal documents relating to taxes, Article 3.5 of General Conditions in Section 007200 shall prevail.

PART 10 – LAWS AND REGULATIONS

- 10.1 The Contractor's attention is directed to the fact that all applicable Federal and State laws, County, Bi-County, local, and municipal ordinances, and the orders, rules and regulations of all authorities having jurisdiction over this work shall apply to the contract throughout, and they will be deemed to be included in the contract the same as though herein written out in full.

END OF SUPPLEMENTARY INSTRUCTIONS TO CONTRACTORS

REQUIRED SUBMISSIONS

TO: PROSPECTIVE OFFERORS

**FROM: PROCUREMENT OFFICE
MONTGOMERY COLLEGE**

A submittal consisting of the Technical Proposal, and the Price Proposal are required when responding to this Request for Proposal. All proposals must be submitted electronically, in two separate PDF file attachments. One attachment shall consist of the Technical Proposal, and the second attachment shall consist of the Price Proposal. Both attachments shall be sent together, in a single email prior to the proposal submission deadline date and time to vendor.proposals@montgomerycollege.edu. Subject line of email must include "Offeror Response to RFP No. E621-004, Physical Education Building Pool Stair 4 Repair, Rockville Campus".

Electronic proposal submittal is based on Eastern Standard Time (EST). **Any proposal received at the above email address, after the EST submittal deadline will be automatically rejected. Proposals sent to other email address other than the above specified will NOT be accepted.**

In addition to the electronic submission, one original hard copy of Technical Proposal Form (Part A) and all Attachments, and Price Proposal including all Attachments shall be submitted on the enclosed Proposal Forms, properly signed with the required Attachments, if any, in separately sealed envelopes and delivered to the following address:

Montgomery College
Central Receiving Office
Attn.: Office of Procurement
7602 Standish Place
Derwood, Maryland 20855

The College Central Receiving Office is currently operating from 10:00 a.m. to 2:00 p.m., Monday through Friday, except for College holidays. . A copy of College academic calendar is available at: <https://www.montgomerycollege.edu/academics/academic-calendar.html>). Contact: James Fowlkes, Central Receiving Supervisor. Cell Phone: (240) 620-2640.

Any size envelope may be used. However, all envelopes must be marked with the Contractor's name and address, RFP number and description for which the proposals are submitted, as well as RFP closing date and time.

PART 1 - ITEMS REQUIRED FOR ALL TECHNICAL PROPOSAL (PART A) SUBMISSIONS

- 1.1 Technical Proposal Form, Section 004213A
- 1.2 Attachments specified in Technical Proposal Form Section 004213A, including:
 - a) Contractor's Qualification Statement including Financial Statements, Section 004513
Contractor is required to provide copies of financial statements for the last two years, preferably audited, including your organization's balance sheet and income statement showing Current Assets, Net Fixed Assets, Other Assets, Current Liabilities and Other Liabilities. Include name and address of firm preparing attached financial statement(s), and date(s) thereof.

Information provided in the Financial Statements is for the express purpose of assisting Montgomery College in its assessment of the Contractor's suitability for providing services as a Contractor for the referenced project.

- b) A copy of Contractor's Maryland License
- c) Subcontractor Information Form(s), Section 004513I (Not Required for Technical Proposal Submission, but Upon Request).

d) Contractor's Relevant Project Experience

- 1) Submit a list of ceiling replacement and painting projects your organization has completed in the last five years, giving the name of the project, owner, architect/engineer, the contract amount, date of completion and percentage of cost of the work performed with your own forces.

Three of the projects included shall be within the Metropolitan Baltimore-Washington region. Document successful completion of projects of similar size, scope and complexity, within the last five years, such as:

- Demonstrated experience with projects whose construction value is similar to this project.
 - Demonstrated experience managing projects with finite schedule requirements
- 2) Submit three (3) of the above relevant project references of similar scope, size and complexity **completed within the past three years**. One (1) of the project references shall be within the Metropolitan Baltimore-Washington areas.

Provide a brief description of the scope of work and list each project's size, construction cost (including general conditions, OH&P), change order value (excluding or annotating Owner directed scope changes), duration of the project and an Owner's reference contact person's name and current telephone number. Please make sure the references and contact persons are current. Use separate sheets if necessary and include them with the submission.

- e) Proposed Project Management/Supervisory Personnel List (including Construction Superintendent) and their Professional Qualifications and Technical Competence.

Contractor shall list the names and describe previous experience by the personnel who will be assigned to the College's project in providing project management and supervision services for construction projects of similar size, complexity and scope together with a statement as to the extent to which these personnel will be full-time or part-time.

- 1) Submit resumes and/or other relevant information demonstrating the qualifications and technical competence of proposed project team members including, at a minimum:
 - Project Manager
 - Quality Control Manager

- 2) Demonstration that team members have prior work experience together is preferred.
- 3) Indicate expected percentage (or range) of time each team member will devote to the project.
- f) Quality Control Program
 - 1) Submit a statement outlining the process by which you will assure compliance with the RFP Documents.
 - 2) Explain how your site housekeeping and maintenance procedures, management of temporary conditions and/or constraints and sequencing of trades affect quality control outcomes.
- g) Verification of Examination of Site Conditions, Section 004400-1
- h) Acknowledgement of Proposed Project Schedule

Include a letter acknowledging review and acceptance of the Proposed Project Schedule as outlined in Part 1 of Section 002213, Supplementary Information to Contractors. Submit an alternative outline schedule for the project if not in agreement with this proposed schedule.
- i) Minority Participation Form, Section 004539
- j) Conflict of Interest Statement, Section 004541
- k) Exceptions to the Montgomery College General Conditions of the Contract, or any deviations to the other RFP requirements, if applicable
- l) Acknowledgement of Receipt of Addenda, if applicable

PART 2 – ITEMS REQUIRED FOR ALL PRICE PROPOSAL FORM (PART B) SUBMISSIONS

2.1 Price Proposal Form, Section 004213B

2.2 AIA Document A310-2010, Bid Bond

- a) If Contractor's total bid amount exceeds **\$100,000.00**, Contractor is required to submit a Bid Bond (**a photo copy included in the electronic submission and an original included in hardcopy submission**) from a surety company authorized to do business in the State of Maryland, acceptable to the College, made payable without condition to the College, for not less than 5% of the total base bid amount, including all add alternates, but excluding deduct alternates, or a cashier's check not less than 5% of the total base bid amount, including all add alternates, but excluding all deduct alternates. Bid Bond shall be prepared and submitted on AIA Form A310-2010, "BID BOND".

2.3 Bonding Company Letter Guaranteeing the Required 100% Performance, Labor and Material Payment Bonds

- a) Contractor shall submit one letter (**a photo copy included in the electronic submission and an original included in hardcopy submission**) from the Contractor's bonding company stating that it guarantees it will furnish the required 100% performance and labor and material

payment bonds if the Contractor is recommended for contract award. Letter provided shall not be generic, but must be written specifically for this project.

END OF REQUIRED SUBMISSIONS

INFORMATION AVAILABLE TO CONTRACTORS

1.1 GENERAL PROVISIONS

- A. College records include documentation that is made available as information to Contractors to illuminate likely project conditions.
- B. Reports, investigations, data, As-Built documentation, and all information related thereto included as Information Available to Contractors are not a part of the Contract Documents.
- C. The College, Architect and Engineers do not guarantee continuity of conditions indicated, and are not responsible for information contained or not contained in the Information Available to Contractors.
- D. Contractors shall employ their own experts to analyze available information. Contractors shall be responsible for the consequences of acting on conclusions obtained from examination and analysis of available information.
- E. Contractors will be responsible for any and all costs associated with obtaining copies of existing record or As-Built drawings. Costs associated with any request for this documentation will be determined by the College at the time of the request, and these costs must be paid for, prior to the release of any documentation to the Contractors.

1.2 BUILDING DOCUMENTATION

Contractors are advised that As-Built documentation is available as reference documents for all project worksites. Documentation may be examined by submitting a written request to:

Yuling Mei, Senior Architect
Email: yuling.mei@montgomerycollege.edu

END OF INFORMATION AVAILABLE TO CONTRACTORS

TECHNICAL PROPOSAL FORM

To: Montgomery College

Re: RFP No.: E621-004
Physical Education Building Pool Stair 4 Repair
Rockville Campus

Attn.: Procurement Office
Montgomery College
9221 Corporate Boulevard
Rockville, Maryland 20850

From: _____
(Provide Your Company's Name)

PART 1 - All proposals must be submitted electronically. Contractor must submit Technical Proposal Form (Part A) and all Attachments in one PDF file, together with the Price Proposal Form (Part B) and all Attachments in a separate PDF file. Both attachments shall be sent together, in a single email to: vendor.proposals@montgomerycollege.edu, prior to the RFP closing date and time, as outlined in RFP. Subject line of email must include “Offeror’s Response to RFP No. E621-004, Physical Education Building Pool Stair 4 Repair, Rockville Campus”. Electronic proposal submittal is based on Eastern Standard Time (EST). Any proposal received at the above email address, after the EST submittal deadline will be automatically rejected. Proposals sent to other email address other than the above specified will NOT be accepted.

In addition to the electronic submission, one original hard copy of Technical Proposal and Price Proposal shall be submitted and delivered to: Montgomery College Central Receiving Office, Attn.: Office of Procurement, 7602 Standish Place, Derwood, Maryland 20855. See detailed submittal requirements in Section 002113 and Section 002413.

PART 2 - Please read the questions, note what is requested, then provide appropriate responses. Failure to answer any of the applicable questions contained in this section will make the proposal non-responsive and be grounds for rejection of the entire proposal. Conditional proposals will not be accepted.

PART 3 - Contractor acknowledges receipt of the following Addenda:

Number _____ Date _____

Number _____ Date _____

Number _____ Date _____

Number _____ Date _____

Number _____ Date _____

PART 4 - The Contractor proposes to provide all of the necessary labor, materials, equipment, and insurance for the replacement and repair of stairs and associated work as indicated in the contract document at Montgomery College's Physical Education Building, Rockville Campus, Maryland as specified in the Request for Proposal documents. The work to be performed by the Contractor shall include all items accepted by the College as part of the Contractor's submittal. It is understood that Montgomery College (hereinafter referred to as College) will be the sole judge as to the acceptance of the proposals and award of the contract. All work shall be done in accordance with the accompanying Technical Specifications and Drawings for the amount listed on the Price Proposal Form, and accepted Alternates, if any, as applicable in accordance with the terms of the Request for Proposal documents. The Contractor is reasonably expected, given the existing conditions and required construction, to complete the Work within the completion date stated in the Request for Proposal documents.

PART 5 - PROPOSAL SUBMITTAL ATTACHMENTS

Technical Proposal Form and all Attachments include:

- A. Contractor's Qualification Statement including Financial Statements, Section 004513-1
- B. Copy of Contractor's Maryland Business Registration
- C. Contractor's Relevant Project Experience
- D. Proposed Project Management/Supervisory Personnel List (including Construction Superintendent) and their Professional Qualifications and Technical Competence
- E. Quality Control Program
- F. Acknowledgement of Proposed Project Schedule
- G. Verification of Examination of Site Conditions, Section 004400-1
- H. Minority Participation Form, Section 004539-1
- I. Conflict of Interest Statement, Section 004541
- J. Any exceptions to the Montgomery College General Conditions of the Contract, or any deviations to the other requirements of the RFP, if applicable
- K. Acknowledgement of Receipt of Addenda, if applicable

PART 6 – The undersigned agrees, if selected as the Contractor, to execute a Contract in accordance with the terms of this Request for Proposal and Contract documents, within five (5) days, Saturdays, Sundays and legal holidays excluded, after presentation thereof by the College.

PART 7 - The undersigned further certifies under the penalties of perjury that this proposal is in every respect bona-fide, fair and made without collusion or fraud with another person, joint venture, corporation, partnership or other business or legal entity.

PART 8 - The undersigned acknowledges the right of the College in its sole discretion to accept any Proposal or to reject any or all Proposals.

PART 9 - SIGNATURES:

(Date) _____ (Company Name)

(Address)

(Telephone Number)

(Facsimile Number)

By: _____
SEAL IF A CORPORATION Authorized Agent & Title (Print)

Signature

(F.E.I.N.)

(Contractor License Number)

(Contact E-mail Address)

BE SURE TO SIGN YOUR PROPOSAL

PRICE PROPOSAL FORM

To: Montgomery College

Re: RFP No.: E621-004
Physical Education Building Pool Stair 4 Repair
Rockville Campus

Attn.: Procurement Office
Montgomery College
9221 Corporate Boulevard
Rockville, Maryland 20850

From: _____
(Provide Your Company's Name)

PART 1 - All proposals must be submitted electronically. Contractor must submit Price Proposal Form (Part B) and all Attachments in one PDF file, together with the Technical Proposal Form (Part A) and all Attachments in a separate PDF file. Both attachments shall be sent together, in a single email to: vendor.proposals@montgomerycollege.edu, prior to the RFP closing date and time, as outlined in RFP. The subject line of the email must include "Offeror's Response to RFP No. E621-004 Physical Education Building Pool Stair 4 Repair, Rockville Campus". Electronic proposal submittal is based on Eastern Standard Time (EST). Any proposal received at the above email address, after the EST submittal deadline will be automatically rejected. Proposals sent to other email address other than the above specified will NOT be accepted.

In addition to the electronic submission, one original hard copy of Technical Proposal and Price Proposal shall be submitted and delivered to: Montgomery College Central Receiving Office, Attn.: Office of Procurement, 7602 Standish Place, Derwood, Maryland 20855. See detailed submittal requirements in Section 002113 and Section 002413.

PART 2 - Please read the questions, note what is requested, then provide appropriate responses. Failure to answer any of the applicable questions contained in this section will make the proposal non-responsive and be grounds for rejection of the entire proposal. **Conditional proposals will not be accepted.** In order to be considered for the award, Contractor must bid all items and fill out all the following blanks. Failure to do so may deem a Contractor non-responsive.

PART 3 - Contractor acknowledges receipt of the following Addenda:

Number _____ Date _____

Number _____ Date _____

Number _____ Date _____

Number _____ Date _____

Number _____ Date _____

PART 4 - BASE PRICE TOTAL (State amounts in both words and numbers where indicated)

The proposed total contract amount to complete **Physical Education Building Pool Stair 4 Repair at Montgomery College Rockville Campus**, per terms, conditions, drawings and specifications, including all costs associated with the requirements specified in the Request for Proposal documents, and having examined both the site of the Work and all matters referred to in the Request for Proposal documents, is:

(In Words): _____ Dollars

(In Numbers): \$ _____

Item #	Description	Dollar Amount (\$)
1	Materials	
2	Labor	
3	Overhead & Profit	
4	Insurance & Performance & Payment Bonds	
5	Base Price Total	

PART 5 - SPECIAL PRICING REQUIREMENTS (State amounts in both words and numbers)

- A. ALLOWANCES – NOT USED
- B. UNIT PRICES – NOT USED
- C. ALTERNATES – NOT USED
- D. SEPARATELY IDENTIFIED PRICES – NOT USED

PART 6- BID SURETY

- A. The bid surety attached in the sum of _____ Dollars (\$ _____) is to become the property of the College in the event the Contract and Bond are not executed with the time set forth, as liquidated damages for the delay and additional expense to the College caused thereby.
- B. The undersigned includes the following submissions as part of the Price Proposal Form:
 Bid Bond (AIA Document A310-2010, “Bid Bond”) if the total bid amount exceeding \$100,000.
 Bonding Company Letter

PART 7 - PRICE PROPOSAL (PART B) SUBMITTAL ATTACHMENTS

- C. AIA Document A310-2010, Bid Bond or Certified Check in an amount not less than 5% of the Base Bid Amount, including all add alternates, but excluding all deduct alternates, if applicable.
- D. Bonding Company Letter Guaranteeing the Required 100% Performance, Labor and Material Payment Bonds

PART 8 – The undersigned agrees, if selected as the Contractor, to execute a Contract in accordance with the terms of this Request for Proposals and the Contract Documents, within five (5) days, Saturdays, Sundays and legal holidays excluded, after presentation thereof by the College.

PART 9 – Upon contract award, the undersigned agrees to hold prices firm for the duration of the overall contract term.

PART 10 - The undersigned acknowledges the right of the College in its sole discretion to accept any Proposal or to reject any or all Proposals.

PART 11 - The undersigned further certifies under the penalties of perjury that this proposal is in every respect bona-fide, fair and made without collusion or fraud with another person, joint venture, corporation, partnership or other business or legal entity.

PART 12 - SIGNATURES:

(Date)

(Company Name)

(Address)

(Telephone Number)

(Facsimile Number)

By:
SEAL IF A CORPORATION

Authorized Agent & Title (Print)

Signature

(F.E.I.N.)

(Contractor License Number)

(Contact E-mail Address)

BE SURE TO SIGN YOUR PROPOSAL

BID BOND

**Physical Education Building Pool Stair 4 Repair
Rockville Campus**

Use AIA Document A310-2010, Bid Bond

VERIFICATION OF EXAMINATION OF SITE CONDITIONS

This form must be completed and included with the Technical Proposal Form (Part A) submission.

The undersigned hereby certifies the completion of examination of the site conditions on _____, 2021.

Date

Company Name

Address

Telephone Number

Facsimile Number

Name & Title (Print)

Email Address

Signature

Site examination inspection confirmed by College Representative:

Date

College Representative Name & Position

Signature

CONTRACTOR'S QUALIFICATION STATEMENT

Use **AIA Document A305, Contractor's Qualification Statement**, latest edition, or Montgomery College's "**Contractor's Qualification Statement**", unless otherwise indicated. A copy of the Montgomery College form and the supplemental instructions are included with this section.

Contractor's Qualification Statement

Preparing the Contractor's Qualification Statement for Review by Montgomery College

Most contractors maintain a generic AIA A305 form. The effort contractors spend adapting the document to our specific interests is noticed and appreciated. The suggestions provided here are intended to help improve your chances of being responsive to our requests for technical information. Our preferences are fairly specific and adherence to these preferences will expedite the review process.

Contractor qualification statements are generally reviewed by a panel consisting of five members. The purpose in using our own form is to obtain objective data in a consistent format that can be easily processed by our panel members. Unfortunately, it has been our experience that many contractors attempt to use the AIA A305 as a way to direct us to a variety of attachments that are in a unique format which are inconsistent or non-responsive to the type of information we are seeking. So, for example when the form requests the value of the contractor's current work (part 3), a somewhat typical response is "see attachment 6" which is a list of projects that may or may not be tabulated. Actually, what we are looking for in that particular space is a dollar amount, not a list. The numbers are certainly not the full story regarding contractor qualifications, but when we ask for a number, our panel members would like to see a current and accurate number in that space.

Where we do ask for project lists, we have found that some lists are more helpful than others. Although we do not require contractors to provide information in a specific format, we do expect the lists to respond to our request for certain basic information. The preferred format and content for our purposes is as follows:

1. A short, descriptive project title, e.g. "new" student center, or "addition to" or "repairs to library building", etc.
2. Owner and location of the work.
3. The name of the architect/engineer.
4. The construction contract value.
5. The year when the project was completed.

The following should be taken into consideration when compiling the project lists:

- a) Since we are a college, we are particularly interested in academic institutional project experience. Highlighting those types of projects is beneficial.
- b) If your project involvement was other than as the sole general contractor or construction manager, please make that clear. Thus, if you are one of multiple primes, or a member of a joint venture, or a subcontractor on the project, please make that distinction in the project title and contract value. Do not claim credit for the entire work.
- c) The project lists serve as client references for our purposes. References are more highly valued when the client is a college, university or other public entity. Local references and recent references are the most relevant.
- d) Project experience becomes increasingly less relevant as the projects become remote in time or distance. We would prefer a short, current and relevant project list.
- e) Failure to provide the requested financials is frequently a cause for disqualification.
- f) We encourage all companies to provide full and accurate information which best presents their qualifications, but please be concise. Too much data or poorly organized data can impede our review and will ultimately be counterproductive.

Finally, the presentation of material including tabs, indexes, and logical organization makes a difference to panel members who are struggling with a large volume of paper. So prepare the submittal accordingly.

Contractor's Qualification Statement

The Undersigned certifies under oath that the information provided herein is true and sufficiently complete so as not to be misleading. Information provided in this statement is for the express purpose of assisting Montgomery College in its assessment of the Offeror's suitability for providing services as a General Contractor for the referenced project.

SUBMITTED TO: Office of Procurement
MONTGOMERY COLLEGE

ADDRESS: 9221 Corporate Boulevard
Rockville, Maryland 20850

SUBMITTED BY:
TITLE:

COMPANY NAME:
ADDRESS:

NAME OF PROJECT: **Physical Education Building Pool Stair 4 Repair**
Rockville Campus

Type of Work (select one):

- General Construction
- HVAC
- Electrical
- Plumbing
- Other (please specify)

1.0 ORGANIZATION

- 1.1 How many years has your organization been in business as a Contractor?
- 1.2 How many years has your organization been in business under its present business name?
 - 1.2.1 Under what other or former names has your organization operated?
- 1.3 Describe the form of your organization (i.e. corporation, partnership, individual, or other) and name the principal(s):

2.0 LICENSING

- 2.1 List jurisdictions and trade categories in which your organization is legally qualified to do business:

3.0 EXPERIENCE

- 3.1 List the categories of work that your organization normally performs with its own forces:

- 3.2 On a separate sheet, list the similar construction projects your organization has completed in the last three years, giving the name of the project, owner, architect, the contract amount, date of completion and percentage of cost of the work performed with your own forces.

- 3.3 State average annual amount of construction work performed in the last three years:

- 3.4 Has your organization ever failed to complete any work awarded to it?

NO YES (*attach details*)

- 3.5 Are there any judgments, claims, arbitration proceedings or suits pending or outstanding against your organization or its officers?

NO YES (*attach details*)

- 3.6 Has your organization filed any law suits or requested arbitration with regards to construction contracts within the last five years?

NO YES (*attach details*)

- 3.7 Has your organization ever been debarred from bidding on State Contracts by the Board of Public Works, or on any other Local, Municipal, County, State or Federal project?

NO YES (*attach details*)

- 3.8 Within the last five years, has any officer or principal of your organization ever been an officer or principal of another organization when it failed to complete a construction contract? (If the answer is yes, please attach details.)

NO YES (*attach details*)

- 3.9 Has your organization ever filed for bankruptcy, receivership or any other similar legal protection to protect it from default? (If the answer is yes, please attach details.)

NO YES (*attach details*)

3.10 Include a brief description of **three (3) projects** in Section 3.2 listing each project's size, relevant features, construction cost (including general conditions, OH&P), change order value (excluding or annotating Owner directed scope changes), anticipated schedule, actual schedule and an Owner's reference contact person's name and current telephone number.

4.0 FINANCIAL STATUS

4.1 Financial Statement

Attach copies of financial statements for the **last two years**, preferably audited, including your organization's balance sheet and income statement showing Current Assets, Net Fixed Assets, Other Assets, Current Liabilities and Other Liabilities. Include name and address of firm preparing attached financial statement(s), and date(s) thereof.

5.0 SIGNATURE

5.1 Dated this ____ day of _____, 2021.

Name of Organization:

By:

Title:

6.0 NOTARY

6.1 _____ being duly sworn deposes and says that the information provided herein is true and sufficiently complete so as not to be misleading.

Subscribed and sworn before me this ____ day of _____, 2021.

Notary Public:

My Commission Expires:

SUBCONTRACTOR INFORMATION FORM

Trade: _____

Name: _____

Address: _____

Telephone: _____

Contact: _____

Average Annual Work performed, in dollars, in the last three years: _____

List three representative projects of comparable size, scope and complexity, completed within the last five years. For each project, indicate client name, project location, completion date, size, cost and major features:

Project # 1 _____

Project # 2 _____

Project # 3 _____

MINORITY PARTICIPATION FORM

CONTRACTORS SHALL COMPLETE THE FOLLOWING:

I HEREBY REPRESENT THAT OUR/MY FIRM IS _____

IS NOT _____

A MINORITY BUSINESS FIRM AS INDICATED BELOW (circle one):

African American (not Hispanic) _____ Hispanic _____ Asian _____

American Indian/Native American _____ Disabled _____ Female _____

**INDICATE EXPECTED MINORITY PARTICIPATION FROM SELF-PERFORMED WORK,
AND/OR WORK PERFORMED BY SUBCONTRACTORS AND/OR VENDORS AS A
PERCENTAGE OF TOTAL CONTRACT PRICE:**

Minority Participation Expectation: _____ % of Base Price Total

I hereby certify that the above information is true and correct, to the best of my knowledge and belief.

Firm Name

Signed Date

Type or Print Name

Title

PROCUREMENT OFFICE QUESTIONNAIRE

RFP Number: E621-004

**RFP Title: Physical Education Building Pool Stair 4 Repair
Rockville Campus**

Please be advised that our company **does not** wish to submit a proposal in response to the above-captioned Request for Proposal for the following reasons:

- Too Busy at this time
 - Not engaged in this type of work
 - Project too large/ small
 - Cannot meet mandatory specifications (Please specify below)
 - Other (Please specify)
-

SIGNATURE

PRINTED NAME

TITLE

DATE

COMPANY

Address

Please return to:

Montgomery College
Procurement Office
9221 Corporate Boulevard
Rockville, Maryland 20850

CONFLICT OF INTEREST STATEMENT

The undersigned hereby affirms and attests that to the best of its knowledge, no Montgomery College trustee, or employee, or spouse, parent, child, brother, sister of the trustee or employee, own assets in this business, and of this date are NOT employed by Montgomery College.

Company Name:	
Printed Name:	
Title:	
Signature:	
Date:	

Montgomery College
Standard Performance Bond

Any singular reference to Contract, Surety, Owner or Other Party shall be considered plural where applicable.

CONTRACTOR (*Name and Address*):

SURETY (*Name and Principle Place of Business*):

OWNER (*Name and Address*):

CONSTRUCTION CONTRACT

Date:

Amount:

Description (*Name and Location*):

BOND

Date (*Not earlier than Construction Contract Dated*):

Amount:

Modifications to this Bond:

CONTRACTOR AS PRINCIPAL

Company:

(Corporate Seal)

None

SURETY

Company:

See Page 3

(Corporate Seal)

Signature: _____
Name and Title:

Signature: _____
Name and Title:

(Any additional signatures appear on the last page)

(*FOR INFORMATION ONLY – Name, Address and Telephone*)

AGENT or BROKER:

OWNER'S REPRESENTATIVE (Architect, Engineer or other party)

1 The Contractor and the Surety, jointly and severally, bind themselves, their heirs, executors, and administrators, successors and assigns to the Owner for the performance of the Construction Contract, which is incorporated herein by reference.

2 If the Contractor performs the Construction Contract in accordance with its terms, the Surety and the Contractor shall have no obligation under this Bond.

3 Whenever the Contractor shall be declared by the Owner to be in default under the Contract, the Surety shall, at its sole expense, within 15 days after Owner having mailed to Surety a copy of the notice of default sent to Contractor, take one of the following actions:

3.1 Arrange for the Contractor, with consent of the Owner, to perform and complete the Construction Contract; or

3.2 Undertake to perform and complete the Construction Contract itself, through its agents or through independent contractors; or

3.3 Obtain bids or negotiated proposals from qualified contractors acceptable to the Owner for a contract for performance and completion of the Construction Contract, arrange for a contract to be prepared for execution by the Owner and the contractor selected with the Owner's concurrence, to be secured with performance and payment bonds executed by a qualified surety equivalent to the bonds issued on the Construction Contract, and pay to the Owner the amount of damages as described in Paragraph 5 in excess of the Balance of the Contract Price incurred by the Owner resulting from the Contractor's default; or

3.4 Waive its right to perform and complete, arrange for completion, or obtain a new contractor and

.1 After investigation, determine the amount for which it may be liable to the Owner and, as soon as practicable after the amount is determined, tender payment therefor to the Owner; or

.2 Deny liability in whole or in part and notify the Owner citing reasons therefor.

4 If the Surety does not proceed as provided in Paragraph 3, the Surety shall be deemed to be in default on this Bond fifteen days after receipt of an additional written notice from the Owner to the Surety demanding that the Surety perform its obligations under this Bond, and the Owner shall be entitled to enforce any remedy

available to the Owner. If the Surety proceeds as provided in Subparagraph 3.4, and the Owner refuses the payment tendered or the Surety has denied liability, in whole or in part, without further notice the Owner shall be entitled to enforce any remedy available to the Owner.

5 After the Owner has terminated the Contractor's right to complete the Construction Contract, and if the Surety elects to act under Subparagraph 3.2 or 3.3 above, then the responsibilities of the Surety to the Owner shall not be greater than those of the Contractor under the Construction Contract. The Surety is obligated without duplication for:

5.1 The responsibilities of the Contractor for correction of defective work and completion of the Construction Contract;

5.2 Additional legal, design professional and delay costs resulting from the Contractor's Default, and resulting from the actions or failure to act of the Surety under Paragraph 3;

5.3 Liquidated damages, or if no liquidated damages are specified in the Construction Contract, actual damages caused by delayed performance or non-performance of the Contractor, and

5.4 All other costs and damages permitted to be recovered by the Owner under the Construction Contractor at law.

6 The Surety hereby waives notice of any change, including changes of time, to the Construction Contract or to related subcontracts, purchase orders and other obligations.

7 Any proceeding, legal or equitable, under this Bond may be instituted only in the Circuit Court for Montgomery County, Maryland and the Surety waives venue in any other court.

8 Notice to the Surety, the Owner or the Contractor shall be mailed or delivered to the address shown on the signature page.

9 This Bond had been furnished to comply with a statutory or other legal requirement of the State of Maryland. Any provision in this Bond conflicting with said statutory or legal requirement shall be deemed deleted herefrom and provisions conforming to such statutory or other legal requirement shall be deemed incorporated herein. The intent is that this Bond shall be construed as a statutory bond and not as a common law bond.

made to or on behalf of the Contractor under the Construction Contract.

10 DEFINITIONS

10.1 Balance of the Contract Price: The total amount payable by the Owner to the Contractor under the Construction Contract after all proper adjustments have been made, including allowance to the Contractor of any amounts received or to be received by the Owner in settlement of insurance or other claims for damages to which the Contractor is entitled, reduced by all valid and proper payments

10.2 Construction Contract: The agreement between the Owner and the Contractor identified on the signature page, including all Contract Documents and changes thereto.

10.3 Contractor Default: Failure of the Contractor, which has neither been remedied nor waived, to perform or otherwise to comply with the terms of the Construction Contract.

(Space is provided below for additional signatures of added parties, other than those appearing on the cover page.)

CONTRACTOR AS PRINCIPAL
Company: _____ (Corporate Seal)

SURETY
Company: _____ (Corporate Seal)

Signature: _____
Name and Title:
Address:

Signature: _____
Name and Title:
Address:

PAYMENT BOND

**Physical Education Building Pool Stair 4 Repair
Rockville Campus**

RFP No.: E621-004

Use AIA Document A312-2010, Payment Bond

APPLICATION AND CERTIFICATE FOR PAYMENT

Use AIA Document G702, Application and Certificate for Payment, latest edition, and relevant attachments, unless otherwise indicated.

**MONTGOMERY COLLEGE
GENERAL CONDITIONS OF THE CONTRACT**

TABLE OF CONTENTS

- 1. GENERAL PROVISIONS**
 - 1.1. DEFINITIONS
 - 1.2. CONTRACT DOCUMENTS
 - 1.2.1. Correlation and Intent of Contract Documents
 - 1.2.2. Specifications Format
 - 1.2.3. Standard Specifications
 - 1.2.4. Ownership

- 2. COLLEGE AND COLLEGE'S AGENTS**
 - 2.1. AUTHORITY OF THE COLLEGE'S PROJECT MANAGER
 - 2.2. RESPONSIBILITY OF THE COLLEGE'S PROJECT MANAGER
 - 2.3. RESPONSIBILITY OF THE COLLEGE DEPARTMENT OF ENVIRONMENTAL SAFETY
 - 2.4. RESPONSIBILITIES OF THE ARCHITECT/ENGINEER
 - 2.5. COLLEGE'S RIGHT TO STOP OR SUSPEND WORK
 - 2.3.1. Stopping of the Work
 - 2.3.2. Suspension of the Work

- 3. CONTRACTOR**
 - 3.1. RESPONSIBILITIES OF THE CONTRACTOR
 - 3.2. CONTRACTOR'S ADMINISTRATION AND SUPERVISION OF THE WORK
 - 3.2.1. Staff
 - 3.2.2. Supervision
 - 3.2.3. Subcontracts
 - 3.2.4. Behavior of Contractor's Employees, Agents and Subcontractors
 - 3.3. MATERIALS, LABOR, EQUIPMENT AND PROCESSES
 - 3.3.1. Proposals
 - 3.3.2. Labor, Materials and Equipment
 - 3.3.3. Use of Named Materials
 - 3.3.4. Use of Equivalent Materials
 - 3.3.5. Substitutions
 - 3.3.6. Required List of Materials and Equipment
 - 3.3.7. Tariffs
 - 3.4. WARRANTY/GUARANTEES
 - 3.5. TAXES
 - 3.6. PERMITS AND LICENSES
 - 3.7. PROSECUTION AND PROGRESS OF THE WORK
 - 3.7.1. Notice to Proceed
 - 3.7.2. Hours of Work
 - 3.7.3. Construction Schedule
 - 3.7.4. Progress Meetings
 - 3.8. REFERENCE DOCUMENTS FOR THE WORK
 - 3.8.1. Conformance Documents
 - 3.8.2. Progress Documents
 - 3.8.3. Record Documents
 - 3.9. SHOP DRAWINGS, PRODUCT DATA AND SAMPLES

- 3.10 SITE INFORMATION, ACCESS, USE AND RESTRICTIONS
 - 3.10.1. Site Information
 - 3.10.2. Campus Coordination Requirements
 - 3.10.3. Coordination where Work is in or adjacent to an Occupied Existing Building
 - 3.10.4. Temporary Facilities
 - 3.10.5. Existing Utilities
 - 3.10.6. Erosion Control
 - 3.10.7. Tree and Plant Protection
 - 3.10.8. Snow and Ice Removal
 - 3.10.9. Trash Removal, Salvage and Recycling
 - 3.10.10. Project Signage
- 3.11 HAZARDOUS AND TOXIC SUBSTANCES
 - 3.11.1. Hazardous and Toxic Substances
 - 3.11.2. Asbestos-Containing Materials
 - 3.11.3. Environmental Litigation
- 3.12 CUTTING AND PATCHING
- 3.13 CLEANING
 - 3.13.1. Progress Cleaning
 - 3.13.2. Final Cleaning
- 3.14 ROYALTIES AND PATENTS
- 3.15 INDEMNIFICATION

- 4. ADMINISTRATION OF THE CONTRACT**
 - 4.1 CLARIFYING INSTRUCTIONS
 - 4.2 REQUESTS FOR INFORMATION
 - 4.3 SITE VISITS AND OBSERVATIONS
 - 4.4 CLAIMS AND DISPUTES
 - 4.5 DELAYS AND DAMAGES

- 5. CONSTRUCTION BY COLLEGE OR BY SEPARATE CONTRACTORS**

- 6. CHANGES IN THE WORK**
 - 6.1 CHANGES IN THE WORK
 - 6.1.1 Changes
 - 6.1.2 Disputed Work
 - 6.1.3 Modification of Contract Sum
 - 6.1.4 Minor Changes in the Work

- 7. PAYMENTS AND COMPLETION**
 - 7.1 SCHEDULE OF VALUES
 - 7.2 PROGRESS PAYMENTS
 - 7.3 ACCEPTANCE OF THE WORK AND FINAL PAYMENT
 - 7.3.1. Partial Acceptance
 - 7.3.2 Substantial Completion and Final Inspection
 - 7.3.3. Application for Final Payment
 - 7.4 ASSIGNMENT OF CONTRACT MONIES
 - 7.5 AUDIT

- 8. PROTECTION OF PERSONS AND PROPERTY**
 - 8.1 SAFETY PRECAUTIONS AND PROGRAMS
 - 8.2 PROTECTION OF PERSONS AND PROPERTY
 - 8.3 FIRE PROTECTION
 - 8.4 EMERGENCIES
 - 8.5 ACCIDENTS

- 9. INSURANCE AND BONDS**
 - 9.1. INSURANCE
 - 9.2. PERFORMANCE, LABOR AND MATERIAL BONDS AND MAINTENANCE BOND

- 10. CORRECTION OF WORK**
 - 10.1 CORRECTION OF WORK
 - 10.1.1 Correction of Work before Final Payment
 - 10.1.2 Correction of Work after Substantial Completion of Work
 - 10.2 ACCEPTANCE OF NON-CONFORMING WORK

- 11. MISCELLANEOUS PROVISIONS**
 - 11.1 LEGAL OBLIGATIONS, RELATIONS AND RESPONSIBILITIES
 - 11.1.1 Laws to be Observed
 - 11.1.2 Regulations
 - 11.2 INDEPENDENT CONTRACTOR
 - 11.3 EQUAL OPPORTUNITY
 - 11.4 COMPLIANCE WITH THE IMMIGRATION REFORM AND CONTROL ACT OF 1986
 - 11.5 ASSURANCE OF NONCONVICTION OF BRIBERY
 - 11.6 CONFLICT OF INTEREST
 - 11.7 ASSIGNMENT AND SUBCONTRACTING
 - 11.8 CONTINGENT FEES
 - 11.9 MARYLAND PUBLIC INFORMATION ACT
 - 11.10 TESTING AND INSPECTION
 - 11.11 NO WAIVER OF RIGHTS – COLLEGE’S REMEDIES CUMULATIVE – COLLEGE’S DAMAGES
 - 11.12 REGISTRATION OF CORPORATIONS NOT INCORPORATED IN THE STATE OF MARYLAND

- 12. TERMINATION OF THE CONTRACT**
 - 12.1. TERMINATION FOR DEFAULT
 - 12.2 TERMINATION FOR CONVENIENCE

ARTICLE 1 – GENERAL PROVISIONS

1.1. DEFINITIONS

1.1.1. The "Agreement" is the written contract between the College and the Contractor.

1.1.2. The "College" is Montgomery Community College or Montgomery College Foundation, Inc.

1.1.3. The "Contractor" is the person or organization having a direct contractual relationship with the College for the execution of the Work under the Contract Documents.

1.1.4. The "Contract Documents" are the Agreement, the Request for Bid or Request for Proposal, Instructions to Bidders/Offerors, Supplementary Instructions, the General Conditions, Supplementary Conditions, Preliminary Project Schedule, Drawings, Specifications, Addenda issued prior to execution of the Contract, Modifications issued after execution of the Contract, the Performance Bond, the Labor and Material Payment Bond, accepted Contractor's Bid or Proposal Form(s) and all attachments thereto received from the Contractor. The term "Contract" when used in the Specifications or Drawings shall be considered as synonymous with the term "Contract Documents".

1.1.5. The "Specifications" are the portion of the Contract Documents included in the Project Manual consisting of the written requirements for materials, equipment, construction systems, standards and workmanship for the Work, and performance of related services.

1.1.6. The "Drawings" are those enumerated in the Specifications and those incorporated in the Contract Documents as the Work progresses.

1.1.7. The "Project Manual" is the volume that includes the Specifications as well as Bidding or Proposal Requirements, Contract Form, General Conditions and Supplementary Conditions.

1.1.8. The term "Work" means all of the obligations undertaken by the Contractor pursuant to the Contract Documents. Work includes, unless specifically excepted, the furnishing of all material, labor, equipment, supplies, plant, tools, scaffolding, transportation, supervision, insurance, taxes and all other services, facilities and expenses necessary for the full performance and completion of the requirements of the Contract Documents. "Work" also means that which is produced, constructed, or built pursuant to the Contract Documents.

1.1.9. The term "Project" is the total construction of which the Work performed under the Contract Documents may be the whole or a part and which may include construction by the College or by separate contractors.

1.1.10. The term "Subcontractor" means any individual, partnership, firm, corporation or business entity other than an employee of the Contractor, who has a contract with the Contractor to furnish labor, or labor and materials for the Work. The term also includes Subcontractors of a Subcontractor. The term does not include vendors who furnish materials not worked to a special design according to the Drawings and Specifications.

1.1.11. The term "Site" or "Premises" means the area or areas indicated and such additional areas or locations upon which or in which Work under this Contract is being performed together with such areas adjacent thereto, as may be designated for the Contractor's use for a specified, limited period of time by the College.

1.1.12. The "Architect/Engineer" is the person commissioned by the College to design the Work and/or provide construction-phase architectural or engineering services. If the design was performed by the College, "Architect/Engineer" shall refer to the College.

1.1.13. The term "Contract Time" or "Time" and "Completion Date" is the number of calendar days (including weekends and holidays) shown in the Contract Documents as the time allowed for completion of the Work. If a calendar date of completion is shown in the Contract Documents in lieu of the number of calendar days, the Work shall be completed on or before that date.

1.1.14. The term "Contract Sum" refers to the total sum, including authorized adjustments, allotted in the Contract Documents for the services performed by the Contractor for satisfactory completion of all of the Work required by the Contract Documents.

1.1.15. "Shop Drawings" are drawings, diagrams, schedules and other data specially prepared for the Work by the Contractor or a Subcontractor, manufacturer, supplier or distributor to illustrate some portion of the Work.

1.1.16. "Product Data" are illustrations, standard schedules, performance charts, instructions, brochures, diagrams and other information furnished by the Contractor or a Subcontractor, manufacturer, supplier or distributor to illustrate materials or equipment for some portion of the Work.

1.1.17. "Samples" are natural materials, fabricated items, equipment, devices, appliances or parts thereof as called for in the Specifications, and any other samples as may be required by the College to determine whether the kind, quality, construction, workmanship, finish, color and other characteristics of the materials, etc., proposed by the Contractor conform to the requirements of the Contract Documents. Samples shall establish the kind, quality and other required characteristics of the various parts of the Work, and all Work shall be in accordance with the accepted samples.

1.1.18. The term "Request for Information" refers to a written instrument submitted by the Contractor requesting that a clarification with respect to the Contract Documents be provided by the Architect/Engineer.

1.1.19. The term "Change Order" refers to a written instrument signed by the College which describes a directive by the College which is a change in the Work.

1.1.20. The "College's Representative" is the Vice President of Facilities & Public Safety or their designee.

1.1.21 The "College's Project Manager" is(are) the person(s) or entity(ies) employed or retained by the College to provide project and construction management services, including administration of the Contract as described in Article 2. The College may exercise any power or authority of the College's Project Manager under the Contract.

1.1.22. "Day" means a calendar day unless otherwise designated.

1.1.23. "Notice to Proceed" means a written notice to the Contractor of the date on which it shall begin the prosecution of the Work. The Contract Time shall begin to run from the starting date established in the Notice to Proceed. Notice to Proceed will be timely provided upon receipt of Contractor materials required before the start of work, including but not limited to performance, payment, labor and material bonds and insurance certificates.

1.1.24. "Written Notice" means giving of notice under the Contract by one party to the other. Unless otherwise indicated in the Contract Documents, Written Notice shall be deemed to have been duly served on the Contractor if delivered in person to the individual or to the member of the firm or to an office of the corporation to whom it is directed, or if delivered by regular or certified mail to the last business address known to the College. Written Notice shall be deemed to have been given to the College upon actual receipt of Written Notice by the College.

1.2. CONTRACT DOCUMENTS

1.2.1. Correlation and Intent of Contract Documents

1.2.1.1. The Contract Documents are complementary, and what is required by any one shall be as binding as if required by all. Their intent is to include in the scope of the Contract, at no additional cost to the College, all Work necessary for proper completion of the Work ready for continual efficient operation that is reasonably inferable from the Documents.

1.2.1.2. Prior to submitting its price, the Contractor shall obtain from the College, clarification of all questions which may have arisen as to the intent of the Contract Documents, or any conflict between two or more items in the Contract Documents. Should the Contractor fail to obtain clarification, then the College may direct that the Work proceed by any method indicated, specified or required by the Contract Documents, in the judgment of the College. The direction by the College shall not constitute the basis for a claim for extra costs by the Contractor. The Contractor acknowledges that it had the opportunity to request clarification prior to submitting its price to the College and that it is not entitled to claim extra costs as a result of failure to request such clarification.

1.2.1.3. The College's Project Manager shall make recommendations regarding the amount, quality, acceptability and fitness of the several kinds of Work and materials which are to be paid for under this Contract and shall make recommendations regarding all questions which may arise in relation to the Work and the construction thereof. The College's decision, based on the College's Project Manager's recommendation, shall be final and conclusive, except as herein otherwise expressly provided. In case any question shall arise between the parties relative to the Contract Documents, the determination or decision of the College shall be a condition precedent to the right of the Contractor to receive payment for the Work under the Contract related to such questions.

1.2.1.4. In the event of conflicts or discrepancies among the Contract Documents, interpretations will be based on the more restrictive condition in consideration of following priorities:

- (1) The Request for Bid or Request for Proposal
- (2) Any modifications to the Contract Documents executed after the date of the Contract, with the Modifications having the latest date having the greatest authority.
- (3) The Contract.
- (4) Supplementary Conditions.
- (5) General Conditions.
- (5) Drawings and Specifications.
- (6) The Contractor's Proposal accepted by the College.

In the event of a conflict or discrepancy within the Specifications or the Drawings, or between the Drawings and the Specifications, the better quality or greater quantity of Work shall be provided in accordance with the College's interpretation.

1.2.1.5. The College's Project Manager and Architect/Engineer shall make recommendations to the College to clarify the meaning and intent of the Specifications and the Drawings where the same may be found unclear or be in dispute.

1.2.1.6. The Contractor is responsible for coordinating and completing the various parts of the Work. No part of the Work shall be left in an unfinished or incomplete condition because of a disagreement between the Contractor and Subcontractors, or between Subcontractors and the Contractor as to where the Work of one begins and ends in relation to the Work of the other. Any adjustments due to differences or conflicts which may arise between the Work of the Contractor under this Contract and the work of other contractors performing work for the College shall be determined by the College and the College's Project Manager.

1.2.1.7. Generally, the Specifications describe Work which cannot be readily indicated on the Drawings and indicate types, qualities and methods of installation of the various materials and equipment required for the Work. The Specifications are not intended to mention every item of Work which can be adequately shown on the Drawings. The Drawings are not intended to show all items of

Work described or required by the Specifications even if they are of such nature that they could have been shown thereon. All materials or labor for Work which are shown on the Drawings, or are reasonably inferable there from as being necessary to produce a finished Work, shall be provided by the Contractor whether or not the Work is also expressly covered in the Specifications.

1.2.2. Specification Format

1.2.2.1. The Specifications are separated into titled sections for convenience only and not to identify the trade or craft responsible to perform the Work. The titled section shall not operate to make the College an arbitrator for the division of responsibility between Contractor and its Subcontractors, and between its Subcontractors, nor shall such sections relieve the Contractor from the responsibility for the satisfactory completion of the entire Work regardless of the division.

1.2.2.2. The General Conditions are a part of each and every section of the Specifications.

1.2.2.3. The Specifications may be abbreviated and include incomplete sentences. Omissions of words or phrases such as "the Contractor shall", "shall be", etc., are intentional; nevertheless, the requirements of the Specifications are mandatory. Omitted words or phrases shall be supplied by inference in the same manner, as they are when a "note" occurs on the Drawings.

1.2.2.4. Words in the singular shall include the plural whenever applicable, or the context so indicates.

1.2.2.5. Where "as shown", "as indicated", "as detailed" or words of similar import are used, reference is made to the Drawings accompanying the Specifications unless otherwise stated. Where "as directed", "as required", "as permitted", "as authorized", "as approved", "as accepted", "as selected", or words of similar import are used, the direction, requirement, permission, authorization, approval, acceptance or selection by the College is intended unless otherwise stated. As used herein, "provide" means "provided complete in place", that is, furnished and installed and ready for operation and/or use.

1.2.3. Standard Specifications

1.2.3.1. Any reference to standard specifications of any society, institute, association or governmental authority is a reference to the standard specifications of such organization and to their methods of installation of the various materials and equipment required for the Work which are in effect at the time prices are due. It is not intended to mention every item of work described or required by the standard specifications even if they are of such nature that they could have been shown thereon. All materials or labor for work which are inferable there from, as the Contractor shall provide being necessary to produce a finished job at the date of the Contractor's price. If such specifications are revised prior to completion of any part of the work to which such revision would pertain, the Contractor may, if acceptable to the College, perform such work in accordance with the revised specifications.

1.2.3.2. The standard specifications, except as modified in the Specifications for the Project, shall have full force and effect as though printed in the Specifications.

1.2.4. Ownership

1.2.4.1. The Drawings, Specifications and other documents prepared by the Architect/Engineer, are owned by the College. Copies thereof furnished to the Contractor, are for use solely with respect to this Project.

ARTICLE 2 – COLLEGE AND COLLEGE'S AGENTS

2.1. AUTHORITY OF COLLEGE'S PROJECT MANAGER

2.1.1. The College's Project Manager has the authority to perform all of the College's functions pertaining to the conduct and administration of the Work, except as indicated in 2.1.2.

2.1.2. Unless otherwise indicated in the Contract Documents, the College's Project Manager is NOT authorized to make determinations (as opposed to recommendations) that:

- 2.1.2.1. Alter or modify the Contract Documents;
- 2.1.2.2. Alter the Contract schedule;
- 2.1.2.3. Approve Contract change orders;
- 2.1.2.4. Terminate or cancel the Contracts.

2.1.3. Unless otherwise indicated in the Contract Documents, recommendations made by the College's Project Manager, pertaining to determinations listed in 2.1.2, are changes in the work that require review, approval and further authorizing action from the College as indicated in Article 6.

2.2. RESPONSIBILITIES OF THE COLLEGE'S PROJECT MANAGER

2.2.1. The College's Project Manager shall be an agent of the College to the extent set forth in the Contract Documents. Any non-College employee in such role shall not be deemed to be the employee of the College for any purpose in connection therewith. Subject to subsection 2.1.2, the College's Project Manager shall have full authority to act, or to cause others to act, on behalf of the College to assure that the Work is carried out in full compliance with the requirements of the Contract, and to otherwise generally protect the College's interests.

2.2.2. The College's Project Manager will determine in general that the Work of the Contractor is being performed in accordance with the Contract Documents, and will use his best efforts to guard the College against defects and deficiencies in the Work of the Contractor.

2.2.3. The College's Project Manager shall provide administrative management and related services as required to coordinate the Work of the Contractor and separate contractors with each other and with the activities of the Architect/Engineer to complete the Project in accordance with the College's objectives for cost, time and quality.

2.3. RESPONSIBILITIES OF THE COLLEGE DEPARTMENT OF ENVIRONMENTAL SAFETY

2.3.1. The Montgomery College Office of Facilities and Public Safety Department of Environmental Safety is responsible for promoting a safe and healthful work environment for the Project and for verifying the Contractor's compliance with Federal and State environmental protection regulations and College safety and health practices. To carry out these responsibilities, the Department of Environmental Safety is authorized to inspect the Project, all work done and being done, and all material to be furnished and being furnished. In the event that the Department learns of an unsafe condition, the Environmental Safety Manager is authorized to suspend work (after notice to the College Project Manager and the Office of Facilities Management) until the unsafe condition is cured by the Contractor. "Unsafe condition" means any practice that represents a significant risk of injury or health hazard to College employees, a significant adverse environmental impact, or a physical hazard which could result in damage to College property and/or the public. The authority of Department of Environmental Safety is in addition to any other rights of the College set forth herein.

2.4. RESPONSIBILITIES OF THE ARCHITECT/ENGINEER

2.4.1. Architect/Engineer's Status

2.4.1.1. The College may maintain staff personnel from the Office of Facilities and Public Safety, or

as separate architectural and/or engineering services retained by the College, at the site of the Work for field observation and day-to-day monitoring of the Work.

2.4.1.2. The Architect/Engineer shall assist the College during the construction period and with the College's Project Manager shall observe the Work in process on behalf of the College. The Architect/Engineer will not be responsible for construction means, methods, techniques, sequences or procedures or for safety precautions and programs in connection with the Work. The Architect/Engineer shall have authority to act on behalf of the College only to the extent expressly provided in the Contract Documents or otherwise in writing.

2.4.1.3. With the College's Project Manager the Architect/Engineer may advise the College with respect to claims of the College or the Contractor, on matters relating to the execution and progress of the Work and on the interpretation of the Contract Documents.

2.4.1.4. Together with the College's Project Manager the Architect/Engineer shall certify applications for progress payments and final payment that the Contractor has complied with the requirements of the Contract Documents.

2.4.1.5. Together with the College's Project Manager the Architect/Engineer shall determine Contractor's achievement of Substantial Completion and Final Completion milestones, and issue relevant certificates, in accordance with the requirements of the Contract Documents.

2.5. COLLEGE'S RIGHT TO STOP OR SUSPEND WORK

2.5.1. Stopping of the Work

2.5.1.1. Subject to concurrence by the College, the College's Project Manager may stop all or part of the Contractor's Work, if in the opinion of the College's Project Manager the Contractor has performed Work not in conformance with the Contract Documents. The Work may be stopped until such time that the defective conditions have been corrected. All costs related to the stoppage of the Work shall be borne by the Contractor.

2.5.2. Suspension of the Work

2.5.2.1. The College unilaterally may order the Contractor in writing to suspend, delay or interrupt all or any part of the Work for a period of time as it may determine to be appropriate.

2.5.2.2. If the performance of all or any part of the Work is for an unreasonable period of time suspended, delayed or interrupted by an act or omission of the College in the administration of the Contract, an adjustment shall be made for any increase in the cost of performance of the Contract (excluding profit) necessarily caused by an unreasonable suspension, delay or interruption and the Contract modified in writing accordingly. No adjustment shall be made under this subsection for any suspension, delay or interruption to the extent (1) that performance would have been so suspended, delayed or interrupted by any other cause, including the fault or negligence of the Contractor; or (2) for which an equitable adjustment is provided for or excluded under any other provision in this Contract.

ARTICLE 3 – CONTRACTOR

3.1. RESPONSIBILITIES OF THE CONTRACTOR

3.1.1. The Contractor shall furnish all labor, materials, equipment, tools, construction equipment, machinery, plant, supplies, utilities, telephone, transportation, supervision, temporary construction, permits, insurance, taxes, bonds, contributions and other facilities and services necessary for proper execution and completion of the Work, whether temporary or permanent and whether or not incorporated or to be incorporated in the Work, as described in the Contract Documents.

3.1.2. Montgomery County or City of Rockville Complex Structures processes may apply to the Project. When applicable, Contractor shall fulfill any necessary obligations related to that process.

3.2. CONTRACTOR'S ADMINISTRATION AND SUPERVISION OF THE WORK

3.2.1. Staff

3.2.1.1. The Contractor shall furnish a competent, qualified and adequate staff as necessary to administer coordinate, supervise and superintend the Work; to organize the procurement of all materials and equipment so that they will be available at the time they are needed for the Work; and to keep an adequate force of skilled workers on the job to complete the Work in accordance with all requirements of the Contract Documents and to the entire satisfaction of the College's Project Manager. Key members of the staff shall not be changed without the consent of the College's Project Manager.

3.2.1.2. Prior to commencement of the Work, the Contractor shall select a project representative who will have full responsibility for the prosecution of the Work, with full authority to act in all matters as necessary for the proper coordination, direction and technical administration of the Work and who shall attend meetings at such place or places as determined by the College's Project Manager in order to render reports on the progress of the Work.

3.2.2. Supervision

3.2.2.1. The Contractor shall efficiently supervise the Work, using its best skill and attention. It shall carefully study and compare all drawings, specifications and other instructions and shall at once report to the College's Project Manager any error or omission which it may discover, and shall subsequently proceed with the Work in accordance with instructions from the College's Project Manager concerning such error or omission.

3.2.2.2. The Contractor shall assign to the Project throughout its duration a well-qualified, competent superintendent and any necessary assistants, all of whom must be satisfactory to the College's Project Manager. The superintendent shall represent the Contractor in its absence and all directions given to him shall be as binding as if given to the Contractor. Important directions shall be confirmed in writing to the Contractor. Other directions shall be so confirmed on written request in each case.

3.2.2.3. The College's Project Manager shall not supervise the Work. The means, methods, techniques, sequences, procedures and safety measures utilized in the performance of the Work are the sole responsibility of the Contractor, subject to overall coordination of the College's Project Manager. Any means, method, techniques, sequences or procedures set forth in the Contract Documents are solely to specify the desired end product; and if the means, methods, techniques, sequences or procedures will not result in the desired end product or is unsafe or illegal because of some inherent defect in the Specifications or the particular conditions under which the Work is being performed, it is the Contractor's responsibility to select a correct means, method, technique, sequence or procedure. Nothing in the College's Project Manager's review of the general quality and progress of the Work, including acceptance of submittals and Work, shall be construed as the assumption of authority or supervision over the performance of the Work, or relieves the Contractor from its obligation to comply with the requirements of the Contract Documents.

3.2.3 Subcontracts

3.2.3.1. The Contractor shall, prior to the execution of the Contract, notify the College in writing of the names of Subcontractors, if any, proposed for the principal parts of the Work and for such other parts of the Work as the College's Project Manager may direct. The Contractor shall not employ any Subcontractor that the College may, within a reasonable time, object to for any reason.

3.2.3.2. The Contractor is as fully responsible to the College for the performance, management, acts and omissions of its Subcontractors and of persons either directly or indirectly employed by them, as it is for the performance, management, acts and omissions of persons directly employed by it.

3.2.3.3. Nothing contained in the Contract Documents shall create any contractual obligation between any Subcontractor and the College.

3.2.3.4. The Contractor agrees to bind every Subcontractor, and every Subcontractor agrees to be bound by the terms of the Contract, the Drawings and the Specifications as far as applicable to its Work, including the following provisions, unless specifically noted to the contrary in a subcontract approved in writing as adequate by the College.

3.2.3.5. The Subcontractor agrees:

- (1) To be bound to the Contractor by the terms of the Contract, the Drawings and the Specifications, and to assume toward the Contractor all the obligations and responsibilities that it, by those documents, assumes toward the College.
- (2) To submit to the Contractor applications for payment in such reasonable time as to enable the Contractor to apply for payment.

3.2.3.6. The Contractor agrees to place in its subcontracts with Subcontractors:

- (1) To be bound to the Subcontractor by all the obligations that the College assumes to the Contractor under the Contract, the Drawings and the Specifications, and by all the provisions thereof affording remedies and redress to the Contractor from the College.
- (2) To pay the Subcontractor, upon the payment of certificates, if listed in the Schedule of Values the amount allowed to the Contractor on account of the Subcontractor's Work to the extent of the Subcontractor's interest therein.
- (3) To make no demand for liquidated damages for delay in any sum in excess of such amount as may be specifically named in the subcontract.
- (4) That no claims for services rendered or materials furnished by the Contractor to the Subcontractor shall be valid unless written notice thereof is given by the Contractor to the Subcontractor during the first ten days of the calendar month following that in which the claim originated.
- (5) To give to the Subcontractor an opportunity to be present and to submit evidence in any decision involving its rights.

3.2.4. Behavior of Contractor's Employees, Agents and Subcontractors

3.2.4.1. The College is committed to providing a work and study environment that is free from discrimination and harassment on the basis of race, color, religious creed, ancestry, national origin, age, sex, marital status, handicap, pregnancy or status as a disabled veteran or veteran of the Vietnam Era. Behavior contrary to this philosophy, which has the purpose or effect of creating an intimidating, hostile, or offensive environment, will not be tolerated by the College, and it is the Contractor's responsibility to ensure that such behavior by its employees, agents and Subcontractors does not occur.

3.2.4.2. This policy extends to maintaining an environment free from sexual harassment. Therefore, sexual advances, sexual remarks, requests for sexual favors, and other verbal or physical conduct of a sexual nature must not be condoned or permitted by the Contractor. This prohibition extends to such

harassment within the employment context as well as harassment of students, staff and visitors of the College. It should be assumed that all sexual behaviors by the Contractor's employees, agents or subcontractors on any campus or facility of the College, whether owned, operated, maintained or leased by the College, is improper and unwelcome.

3.2.4.3. Montgomery College is a tobacco free institution. Use of tobacco products is prohibited in all indoor and outdoor College-owned facilities and facilities leased and controlled by the College as well as at meetings or conferences sponsored by the College. This use prohibition extends to Contractors' employees, agents, subcontractors and vendors.

3.3. MATERIALS, LABOR, EQUIPMENT AND PROCESSES

3.3.1. Proposals

3.3.1.1. Proposals shall be based upon the materials, equipment or processes specifically named, implied in or reasonably inferable from the Contract Documents.

3.3.1.2. In cases where Work is to be performed in an existing building, proposals shall be based on Contractor's review of existing conditions by means including but not limited to: site inspection and review of existing College documentation, if any, including data from the Environmental Safety Office. Failure or omission of the Contractor to inspect the site and examine available documents shall in no way relieve the Contractor from obligations with respect to its price, nor constitute grounds for a subsequent claim.

3.3.1.3. Certain Project proposals shall be based on Prevailing Wage Rate schedule provided by and the reporting requirements of the State of Maryland's Department of Labor, Licensing and Regulation (DLLR). If guidance regarding applicability of Prevailing Wage Rates is not otherwise included in the Contract Documents, Contractor shall request a determination of applicability from the College prior to submitting a proposal.

3.3.2. Labor, Materials and Equipment

3.3.2.1. The Contractor shall enforce strict discipline and good order among the Contractor's employees and other persons carrying out the Contract.

3.3.2.2. The Contractor shall furnish sufficient forces to ensure the prosecution of the Work within the time stated in the Contract.

3.3.2.3. The Contractor shall comply with the provisions of Sections 17208 entitled Prevailing Wage Rates, when applicable, and 17301 through and including 17306 of the State Finance and Procurement Article of the Annotated Code of Maryland (as amended from time to time) entitled "Steel Procurement for Public Works."

3.3.2.4. Unless otherwise specified, all materials and equipment to be permanently installed in the Work shall be new, and shall be of such quality as required to satisfy the standards of the Contract Documents. The Contractor shall, if required, furnish satisfactory evidence as to kind and quality of all materials and equipment.

3.3.2.5. The Contractor shall not permit employment of unfit persons or persons not skilled in tasks assigned to them. All labor shall be performed by workers skilled in their respective trades, and Work produced shall be of good quality so that first class Work in accordance with the standards of construction set forth in the Contract Documents will result.

3.3.3. Use of Named Materials

3.3.3.1. Where materials are specified by a name, or several names are specified, without the words 'or equal' following such name(s) the Contractor shall use and/or supply the named material that meets all the requirements of the Specifications.

3.3.4. Use of Equivalent Materials

3.3.4.1. Where the words 'or equal' are included, at the Contractor's sole risk, the Contractor may submit a material it considers to be equal in quality, capacity, size, or other determining criteria. The burden of submitting adequate information to the College to prove equality of materials shall be the responsibility of the Contractor. A direct comparison of features and fit with the specified item must be included. Whether an equal or specified product is proposed, all of the units of a given type required for and used in the Work must be the same in material and manufacture. The decision of the College with regard to quality of materials shall be final. The College may reject a proposed equal without cause and the Contractor shall not be entitled to additional compensation.

3.3.5. Substitutions

3.3.5.1. Substitutions requests will be considered only under the following circumstances:

- (1) When the specified product is not available; or
- (2) When, if a certain product or process is specified and a guarantee of performance is required and, in the judgment of the Contractor, the specified product or process will not produce the desired results; or
- (3) When a substitution, in the opinion of the College is in its best interest.

3.3.5.2. Requests for substitutions of products, materials or processes other than those specified shall be submitted in writing to the College's Project Manager and be accompanied by evidence that the proposed substitution: (1) is equal in quality and service-ability to the specified item; (2) will not entail changes in details and construction of related work; and (3) will be acceptable in consideration of the required design and artistic effect. The Contractor will furnish with its request such drawings, specifications, samples, performance data and other information as may be required of it to assist the College in determining whether the proposed substitution is acceptable. A direct comparison of features and fit with the specified item must be included. The substitution request shall state the credit or extra, if any, involved with the use of such material. The burden of proof shall be upon the Contractor.

3.3.5.3. Regardless of the evidence submitted or any review or independent investigation by the College, a request for a substitution of products, materials or processes is a warranty by the Contractor to the College that (1) the requested substitution is equal in quality and serviceability to the specific item; (2) will not entail changes in details and construction of related work; (3) will be acceptable in consideration of the required design and artistic effect; (4) will not involve any additional cost to the College other than that specified in an accompanying request for a change order; and (5) the Contractor will provide the same or better warranty for the substitution that the Contractor would for that specified.

3.3.5.4. The College's acceptance of a substitution does not relieve the Contractor of responsibility for any unforeseen consequences and/or costs associated with the substitution.

3.3.5.5. The College may reject a proposed substitution without cause.

3.3.6. Required List of Materials and Equipment

3.3.6.1. Unless otherwise indicated in the Contract Documents, the Contractor shall submit to the College's Project Manager a comprehensive list of the manufacturer's products proposed for this Work as soon as practicable and within thirty (30) calendar days after receipt of notice to proceed. The list

shall include information on materials, equipment and fixtures as may be required for the College's Project Manager's preliminary review; partial lists will not be considered. Acceptance of this list of products shall not be construed as a substitute for the shop drawings, manufacturer's descriptive data and samples which are required by the Contract Documents, but rather as a base from which more detailed submittals shall be developed for the College's final review.

3.3.7. Tariffs

The Contractor's Contract Sum shall be presumed to include all tariffs levied on materials, supplies, equipment or other property incorporated into or used on the Project, whether the tariff is imposed before or after the Contract is signed.

3.4. WARRANTY/GUARANTEES

3.4.1. Except to the extent that the Contract Documents impose greater warranty obligations on the Contractor for all or any part of the Work, the Contractor warrants:

3.4.1.1. That the materials and equipment furnished under the Contract will be of good quality and new unless otherwise required or permitted by the Contract Documents;

3.4.1.2. That the Work contains no faulty or imperfect material or equipment or any imperfect, careless or unskilled workmanship;

3.4.1.3. That all mechanical and electrical equipment, machines, devices, etc., shall be adequate for the use to which they are intended and shall operate with ordinary care and attention in a satisfactory and efficient manner; and

3.4.1.4. That the entire Work shall be watertight and leak proof in every particular.

3.4.1.5. Unless otherwise indicated in the Contract Documents, for a period of one year commencing on the date of Substantial Completion or such other date agreed upon, the Contractor shall schedule, manage and monitor all warranty call-backs requested by the College and re-execute, correct, repair, or remove and replace with proper Work, without cost to the College, any Work found not to be as guaranteed by this section or otherwise not in conformity with the Contract and that it will make good all damages or cost to other Work or materials in the process of complying with this section in accordance with Article 10, Correction of Work. The Contractor shall pay for tests and inspections made necessary by faulty Work. The correction period shall be extended with respect to portions of Work first performed after Substantial Completion by the period of time between Substantial Completion and the actual performance of the Work. This obligation shall survive Final Completion of the Work under the Contract and the Contract Close Out.

3.4.2. Nothing contained in Subsection 3.4.1.5 shall be construed to establish a period of limitation with respect to other obligations which the Contractor might have under the Contract Documents. Establishment of time period of one year as described in Subsection 3.4.1.5 relates only to the specific obligation of the Contractor to correct the Work and has no relationship to the time within which the obligation to comply with the Contract Documents may be sought to be enforced nor to the time within which proceedings may be commenced to establish the Contractor's liability with respect to the Contractor's obligations other than specifically to correct the Work.

3.4.3. The Contractor shall cause to be assigned to the College all warranties/guarantees furnished by manufacturers and suppliers of equipment and supplies for the Work. The assignment shall not affect Contractor's warranty obligations to the College.

3.5. TAXES

3.5.1. The College is not exempt from payment of Maryland State Sales Tax and Municipal Occupation (Sales) and/or Use Taxes on materials purchased for this Work.

3.5.2. The Contractor and Subcontractors shall pay sales, consumer, use, unemployment, old age pension and/or other taxes imposed by local, state and/or the Federal government, except taxes and assessments on the real property comprising the Work site. The Contractor is to include such expenses in its proposal.

3.6. PERMITS AND LICENSES

3.6.1. The College will file for the building permit, if one is necessary, with the local authority. The Contractor shall obtain and pay for any and all permits (other than the building permit), and for all licenses and certificates of inspection necessary for the execution and completion of the Work as called for in the Contract Documents. The Contractor will be required to pay all necessary fees to local authorities for permits and inspections and it shall include the cost of the fees in its base price. The College shall not be responsible for the actions or interpretations of county, municipal or other local agencies or officials with respect to the application of Federal, State or local laws, rules, ordinances, regulations, codes or policies to the Work.

3.6.2. The Contractor must be licensed as required by Title XVII, Subtitle VI or Title VIII of the Business Regulation Article, Annotated Code of Maryland.

3.7. PROSECUTION AND PROGRESS OF THE WORK

3.7.1. Notice to Proceed

3.7.1.1. After the Contract has been executed, the College's Project Manager will issue to the Contractor a "Notice to Proceed" and this notice will stipulate the date on or before which the Contractor is expected to begin Work. The specified Contract time shall begin on the starting date stated in the "Notice to Proceed." Any Work started or materials ordered before the starting date stated in the "Notice to Proceed" shall be at the risk of the Contractor.

3.7.1.2. Notice to Proceed will not be issued until the College receives from the Contractor performance, labor and material payment bonds, insurance certificates and other documents which are required by the Contract. The Contractor is prohibited from performing any Work on the site until proof of the insurance required by the Contract is provided to the College.

3.7.2. Hours of Work

3.7.2.1. The Work shall be performed during regular working hours except in the event of emergency, or when required to complete the Work within the time stated in the Contract. What constitutes regular working hours will be agreed upon at the preconstruction conference.

3.7.2.2. The Work shall be suspended on the College's Commencement Day (typically the third Friday in May) unless otherwise agreed to by the College.

3.7.2.3. The Work may be performed on night shifts, overtime, Sundays and holidays when permission to do so has been obtained from the College, at no additional cost to the College, and provided that Contractor complies with any additional regulations regarding off-hours work mandated by regulatory authorities.

3.7.3. Construction Schedule

3.7.3.1. Time

- (1) All time limits in the Contract Documents are of the essence of the Contract. Contractor and the College agree that the time stated in the Contract for the completion of the Work

is a reasonable time, considering the usual climatic range and the usual business conditions prevailing in the locality of the Project. The Contract time shall be the full time allowed or required for completion of every task involved in completion of the Work, including lead-time for ordering and fabrication of equipment and materials.

- (2) The College is not obligated (a) to accept an early completion schedule from the Contractor, or (b) to accept the Project prior to the completion date stated in the Contract. The College will not be liable for any claims based on the Contractor's assertion of an intention to finish early.

3.7.3.2. Preliminary Schedule

- (1) The Contractor shall agree to comply with the Preliminary Project Schedule prepared by the College and included in the Contract Documents or with the Contractor's Proposed Project Schedule, if one was required as part of the Contractor's proposal submission. Agreement by the Contractor to comply with the Preliminary Project Schedule or Contractor's Proposed Project Schedule also means agreement by the Contractor to comply with subsequent reasonable updates prepared or requested by the College.
- (2) Within 14 days of the execution of the Contract, Contractor must submit for approval, Preliminary Schedule information outlining all activities for the Contractor's work as may be reasonably requested by the College's Project Manager. Coordinate schedule information with milestones indicated in the Preliminary Project Schedule. This preliminary information must be approved prior to the first Application for Payment being processed. Include each significant construction activity, coordinate each activity with other activities and schedule each construction activity in proper sequence. The College's Project Manager may decline to issue a Notice to Proceed until Contractor has submitted the required schedule information and it is approved by the College's Project Manager. Nothing in this section shall be construed to require the College's Project Manager to issue a Notice to Proceed when the required schedule information has been submitted and approved.
- (3) With submission of the preliminary schedule information, include a listing by date of submission of all submittals required. Identify those required to maintain orderly progress of the Work, and those required early because of long lead time for manufacture or fabrication.

3.7.3.3. Completion Schedule

- (1) Within 30 days after Contract execution and at such other times as required by subsections 3.7.3.4 and 3.7.3.8, the Contractor shall submit for approval, updated schedule information indicating the time allocated by the Contractor for the performance of each portion of the Work and the submittal information required by subsection 3.7.3.2 (3), properly and reasonably sequenced for achieving each task shown on the schedule. Coordinate schedule with milestones indicated in the Preliminary Project Schedule.
- (2) The Contractor's construction schedule shall begin with the date of issuance of Notice to Proceed and conclude with the required date of final completion of the project as stated in the Contract Documents. Float or slack time available in the schedule at any time shall not be for the exclusive use or benefit of either the Contractor or the College, but is jointly owned.
- (3) The Contractor's schedule information shall include a complete itemized breakdown of the Work, listed by activity or event number, including items related to the General Conditions, all necessary dates for submittal, review and response, and re-submittal (if necessary), and for each activity shall show at a minimum: (1) a sequence of operations; (2) the dates of commencement and completion of each item of the Work; and (3) delivery for material and equipment. Unless otherwise indicated in the Contract Documents or agreed upon by the College's Project Manager the duration of each activity shall be twenty-one calendar days or less.
- (4) Contractor shall submit with each Application for Payment revised schedule information

- accurately updated to reflect all: (1) revisions to the schedule (2) changes made or planned in the construction sequence; (3) actual construction activities to date including (i) commencement and completion dates for activities started or completed during the reporting period; and (ii) current progress of activities started in prior reporting periods including completion dates for activities completed during the reporting period; (4) delays and their effects on the critical path; (5) extensions of time granted by the College and (6) the Contractor's planned schedule or recovery schedule for completing remaining activities. This required schedule information update shall be furnished monthly whether or not Contractor submits an application for payment in that month.
- (5) In the event that there are change orders, they shall be reflected as new activities, or as changes in logic and/or time framing of existing activities. They shall be introduced at the next updating after receipt of a change order, and shall be subject to the approval of the College's Project Manager. Change order logic shall affect only those intermediate activities and performance dates directly concerned. Adjustments required in completion dates for those intermediate dates, or for the Contract as a whole, will be considered only to the extent that there is not sufficient remaining float to absorb the additional time which may be authorized for completion of individual activities.
 - (6) Whenever the Project shall be behind schedule or alleged by either party to be behind schedule, the College may require the Contractor to furnish, at no additional cost to the College revised schedule information (hereinafter called a "recovery schedule") showing how the Contractor will finish their work by the Contract completion date.
 - (7) All of Contractor's schedule information, including monthly schedule information updates and any recovery schedule information required shall be subject to review and approval by the College's Project Manager.
 - (8) The Contractor shall cooperate with the College's Project Manager in scheduling and performing the Contractor's Work to avoid conflict, delay in or interference with the Work of other contractors or the construction or operation of College's own forces. The Contractor shall participate with other contractors and the College's Project Manager and College in reviewing schedules when directed to do so. The Contractor shall make any revisions to their construction schedule information deemed necessary after a joint review.
 - (9) Approval by the College's Project Manager of any schedule information submitted shall constitute approval of the schedule information only for general conformity with Contract requirements and shall not constitute approval, acceptance or admission of the reasonableness, accuracy, achievability, or feasibility of the schedule information or of the Contractor's ability to meet the schedule, or waiver or excuse of default or delay by the Contractor, extension of the time for completion, waiver or modification of Contract requirements, admission of fault or responsibility for delay on the part of the College or acceptance or admission on the part of the College of any liability or responsibility for the schedule or for acceleration or other costs or delay damages of the Contractor which are inferable from the Contractor's schedule information or update.
 - (10) The College is not obligated to pay the Contractor for Work completed until proper, accurate schedule information, and updates are furnished as required and it is not liable for and Contractor is not entitled to damages, compensation, or time extensions for delays starting, occurring or continuing during the period when an accurate and reasonable schedule information or update was due but not furnished by the Contractor.

3.7.3.4. All schedule information, including initial schedule information, recovery schedule information and monthly updates, shall be submitted in three (3) paper copies and one (1) electronic copy in Portable Document Format (PDF), unless otherwise indicated.

3.7.4. Progress Meetings

3.7.4.1. Contractor shall plan and participate in routine Project progress meetings to brief College's Project Manager and Architect/Engineer on the status of the Project. Frequency of meetings shall be

determined at a preconstruction conference, but shall typically occur not less than every two weeks. Primary agenda topics shall include reporting status of: Regulatory Approvals, Submittals, RFIs, Commissioning, Safety, Security and Housekeeping, Schedule, Contracts/Finance and Close-Out. Unless otherwise indicated in the Contract Documents, record meeting minutes will be prepared by the Contractor.

3.7.4.2. Contractor shall provide reasonable advance notice to the College's Project Manager and Architect/Engineer regarding scheduling of pre-construction and pre-installation conferences with subcontractors. At a minimum, Contractor should anticipate College's participation in conferences related to underground work, demolition work, primary structural work, all building enclosure work, MEP and telecommunications, AV and security systems work.

3.7.5. Progress Meeting Documentation and Reports

3.7.5.1. Contractor shall prepare, maintain, monitor and make available to the College, reasonable Project progress documentation including, but not limited to:

- (1) Contractor's Daily Reports: listing weather conditions, trades on site, manpower, brief description of activities underway, quality control issues raised, commissioning activities underway and any safety or security issues encountered. Append Daily Reports from Subcontractors to the Contractor's Daily Report.
- (2) Minutes from Pre-Construction and Pre-Installation conferences.
- (3) Minutes from Contractor's Subcontractor and/or Foreman's meetings: including agenda topics, brief summary of issues discussed resolutions discussed and issues requiring attention.
- (4) Inspection reports provided by Independent Testing Agencies and/or Laboratories, when applicable.
- (5) Inspection reports provided by any authorities having jurisdiction on the Project.

3.8. REFERENCE DOCUMENTS FOR THE WORK

3.8.1. Conformance Documents

3.8.1.1. The College may issue conformance documents, incorporating all Addenda issued during the bid/proposal period into the Contract Documents, for the Contractor's convenience at the start of Work. It is the Contractor's sole responsibility to verify the accuracy of the conformance documents. At the Contractor's election, conformance documents may serve as the basis for Progress Documents. Use of such documentation shall not in any way relieve the Contractor from its responsibility to perform the Work in accordance with the Contract Documents. In the event of a discrepancy between the conformance documents and the Contract Documents, the Contract Documents shall govern.

3.8.2. Progress Documents

3.8.2.1. The Contractor shall keep one complete set of all Drawings, Specifications, Construction Progress Schedule, and shop drawings at the job-site current and in good order. As the Work progresses, the Contractor shall keep a complete and accurate record of all changes or deviations from the Contract Documents, indicating the Work as actually installed. All underground utility locations associated with the scope of work, or revealed during the conduct of the work, shall be recorded by the Contractor's surveyor and referenced to a campus benchmark provided by the

College. All such changes shall be neatly and correctly shown on black line prints of the drawings affected, or in the Specifications, with appropriate supplementary notes. This record set of prints of Drawings, shop drawings and Specifications shall be kept at the job site for inspection by the College's Project Manager and Architect/Engineer.

3.8.3. Record Documents

3.8.3.1. At the completion of the Work, the Contractor shall certify by endorsement thereof, that each

of the revised prints of the Drawings and Specifications is complete and accurate. Prior to the Contractor's Application for Final Payment, and as a condition to its approval by the College, the Contractor shall assemble its record drawings and specifications, review them for completeness and submit them to the College's Project Manager. The Contractor shall provide suitable transfer cases and deliver the records therein, indexed and marked for each division of the Work.

3.8.3.2. No review or receipt of such records by the College's Project Manager shall be a waiver of any deviation from the Contract Documents or the Shop Drawings or in any way relieve the Contractor from its responsibility to perform the Work in accordance with the Contract Documents and the Shop Drawings to the extent they are in accordance with the Contract Documents.

3.9. SHOP DRAWINGS, PRODUCT DATA AND SAMPLES

3.9.1. After checking and verifying all field measurements and after complying with applicable procedures specified in the Contract Documents, Contractor shall submit to the College's Project Manager and Architect/Engineer, in accordance with the Contractor's schedule, Shop Drawings and other submittals which will bear a stamp or specific written indication that the Contractor has satisfied its responsibility under the Contract Documents with respect to the review of such submissions. The data on the Shop Drawings or submittal must be complete with respect to quantities, dimensions, specified performance and/or design criteria, materials and similar data to enable the Architect/Engineer to review the information as required. These documents shall be prepared in conformity with the best practice and standards for the trade concerned. Due regard shall be given to speed and economy of fabrication and erection.

3.9.2. Obtaining electronic documentation to aid in the preparation of Shop Drawings and submittals shall be the sole responsibility of the Contractor and may be subject to certain terms and conditions required by the Architect/Engineer and/or College. The College cannot guarantee that electronic documentation prepared by the Architect/Engineer will be made available to the Contractor. If provided, Contractor shall not be entitled to rely on such documentation for accuracy and use of such documentation shall not in any way relieve the Contractor from its responsibility to perform the Work in accordance with the Contract Documents.

3.9.3. The Contractor shall prepare and routinely update a submittal log indicating the status of submittals.

3.9.4. Unless otherwise indicated in the Contract Documents or agreed to by the College in writing, the Contractor shall send the College one copy of all Shop Drawings and product data coincident with the initial and any subsequent submissions to the Architect/Engineer. The College will forward any comments it desires to make to the Architect/Engineer within the designated review time.

3.9.5. In addition to the items noted in the Specifications as requiring Shop Drawings or other details, Shop Drawings and details shall be required for all items which are specifically fabricated for the Work or when the assembly of several items is required for a working unit.

3.9.6. The College's Project Manager and Architect/Engineer will examine the Shop Drawings and product data submittals with reasonable promptness. The College's Project Manager and Architect/Engineer will note whether they are approved, approved with corrections and/or conditions, or rejected. The Architect/Engineer will return the Shop Drawings and project data submittals with the final action to the Contractor and also provide one copy each to the College and College's Project Manager.

3.9.7. The Contractor must allow the Architect/Engineer, College's Project Manager at least fourteen calendar days following receipt of each submittal or re-submittal of Shop Drawings and product data submittals to review the documents and respond to the Contractor. Items requiring longer than fourteen calendar days of review time will be identified in the Specifications. The minimum time allowed for the Architect/Engineer, College's Project Manager to review the submittal shall be increased to the extent that additional time for review is needed due to the fault or the responsibility of the Contractor or its Subcontractors and suppliers. The Contractor will be notified of the cause of the delay and advised of how

long it will take to complete the review; provided, however, that mere failure to give the Contractor such notice shall not entitle the Contractor to compensation or a time extension.

3.9.8. When the Architect/Engineer, College's Project Manager or the College desires corrections, or rejects the Shop Drawings, the Contractor shall resubmit the Shop Drawings with the required corrections in a timely manner.

3.9.9. Unless the Contractor has, in writing, at the time of the submissions, expressly notified the Architect/Engineer, College's Project Manager and the College to the contrary, the College and the Architect/Engineer may assume that Shop Drawings and other submittals from the Contractor are in conformity with the Contract Documents and do not involve any change in the Contract price, or any change which will alter the space within the structure, or alter the nature of the building or Work from that contemplated by the Contract Documents, or constitute a substitution of material or equipment or a change in the Contract or the scope of Work. If the Contractor fails to give notice strictly in accordance with this subsection, approval of any Shop Drawing or submittal shall not be binding on the College.

3.9.10. The Contractor shall perform no portion of the Work requiring submittal and review of Shop Drawings, product data, samples and similar submittals until the respective submittal has been approved by the Architect/Engineer. Such Work shall be in accordance with accepted submittals. Work performed without approval shall be at the Contractor's risk.

3.9.11. Shop Drawings, product data, samples and similar submittals shall be marked, tagged, or otherwise properly identified with the name of the Contractor, the name of the Project, the purpose for which the samples are submitted, and the date and shall be accompanied by a letter of transmittal containing similar information, together with the Specification section number for identification of each item. Each tag or sticker shall have clear space for the stamps of the Contractor, College's Project Manager and the Architect/Engineer.

3.9.12. Samples of materials which are generally furnished in containers bearing the manufacturers' descriptive labels and printed application instructions shall, if not submitted in the standard containers, be supplied with such labels and application standards.

3.9.13. Should the Contractor consider any rejection or notation on the Shop Drawings or other submittals by the College's Project Manager or Architect/Engineer or any other action or inaction of the College's Project Manager or the Architect/Engineer to cause a change in the scope of the Work from that required by the Contract Documents, whether or not such change may affect contract price or time, then the Contractor shall desist from further action relative to the item in question and shall in writing (1) immediately notify the Architect/Engineer, the College and College's Project Manager requesting clarification; and (2) furnish them, within seven (7) days, with a notice explaining the nature of the change and whether increased or decreased cost and/or time is anticipated. No Work concerning the Shop Drawing or other submittal in question shall be executed until the entire matter is clarified and the Contractor is ordered by the College to proceed. Failure of the Contractor to serve written notice as required above shall constitute a waiver of any claim in relation thereto.

3.10. SITE INFORMATION, ACCESS, USE AND RESTRICTIONS

3.10.1. Site Information

3.10.1.1. Contractor shall review existing conditions and related College record information to become completely familiar with site and adjacent conditions. Contractor shall make arrangements to review available documentation and undertake explanatory site visits with College's Project Manager and Campus Facilities Office.

3.10.2. Campus Coordination Requirements

3.10.2.1. Contractor shall furnish a Site Mobilization Plan to the College's Project Manager for review and approval prior to the start of Work. Plan shall indicate features including proposed construction delivery route, materials and trash storage areas, site office and toilet facility locations, fencing, erosion control measures, tree and plant protection, temporary lighting, temporary traffic control measures and signage.

3.10.2.2. Contractor shall meet with Campus Facilities and Security Offices prior to the start of Work to review Contractor's proposed Site Mobilization Plan, and to coordinate Project needs with Campus Operations and Maintenance, House and Grounds-keeping and Security operations.

3.10.2.3. In the event that Contractor's operations affect or disrupt campus access roads and/or building entrances or exits, Contractor shall coordinate maintaining or re-directing access in accordance with the Contract Documents and following the direction and policies of the Campus Security Office and any affected emergency service providers.

3.10.2.4. Contractor shall meet with College's Environmental Safety Office prior to the start of Work for projects where Hazardous Materials Abatement or use of Hazardous or Toxic Substances is expected.

3.10.2.5. Any Utility shut down required must be scheduled with relevant utility Owner and Campus Facilities at least 5 days in advance.

3.10.2.6. Unless otherwise indicated in the Contract Documents, vehicular and pedestrian access to properties shall be maintained operational to the maximum possible extent. Driveways to private properties shall not be blocked. Sidewalks and crossings shall be kept open for the passage of pedestrians. Streets shall not be unnecessarily obstructed and, unless the College shall authorize the complete closing of a street, the Contractor shall take such measures as may be necessary to keep the street open for traffic. The Contractor shall provide and maintain suitable and sufficient provisions, including but not limited to flag persons, barricades, warning signs and detour signs, necessary for the protection of the work and safety of the public. All barricades, obstructions and signage shall be illuminated from sunset to sunrise, daily.

3.10.2.7. Parking at all campus locations is limited. Other than one or two spaces for supervisory personnel, parking space for construction site personnel in campus parking lots should not be anticipated. For Projects where Work is confined within a site construction fence, Contractor may provide limited parking for construction personnel within that fenced area as long as parking does not impede progress of the Work or impede access by emergency or campus service vehicles.

3.10.3. Coordination where Work is in or adjacent to an Occupied Existing Building

3.10.3.1. In cases where Work is scheduled to take place in or adjacent to occupied existing buildings, Contractor shall coordinate the Work as reasonably directed by the College's Project Manager to reduce impact of construction operations on building occupants.

3.10.3.2. Noise that disrupts classes cannot generally be tolerated. The Contractor shall notify the College's Project Manager before starting any Work which might disrupt classes. Notification shall be given well in advance of any such situation in order that the Contractor and College's Project Manager

together can reach a mutually agreeable time in which the Work can be accomplished. Noise of a brief/infrequent nature may not be found necessary to reschedule. Always contact the College's Project Manager if in doubt. Any rescheduling required due to noise aversion will not be a cause for either a delay or cost claim.

3.10.3.3. When requested, Contractor shall provide a detailed adjacent Work coordination plan indicating information including schedule of activities, limits of disturbance, sequence of construction, access points and their management, barriers, interface with controls such as fire alarm, security or building automation systems operation, for areas that directly interface with or are affected by the Work.

3.10.4. Temporary Facilities

Unless otherwise indicated in the Contract Documents:

3.10.4.1. The Contractor shall be responsible for arranging with the College's Project Manager for general services and temporary facilities as required for the proper and expeditious prosecution of the Work; including but not limited to: use of toilets; temporary storage; temporary electrical power; and temporary water.

3.10.4.2. The Contractor shall, at its own expense, make all temporary connections to utilities and services in locations acceptable to the College's Project Manager and local authorities having jurisdiction thereof; furnish all necessary labor and materials, and make all installations in a manner subject to the acceptance of such authorities and the College's Project Manager; separately meter and pay for utilities (electricity, water, sewer, and telephone) consumed; maintain such connections; remove the temporary installation and connections when no longer required; restore the services and sources of supply to proper operating conditions.

3.10.4.3. The Contractor shall supply and maintain an office trailer or shed and a telephone, telefax, and/or computer on the site for the purpose of facilitating construction coordination and communication.

3.10.4.4. At the completion of the Work, Contractor's onsite facilities shall be removed, and the site restored to conditions that meet or exceed those existing at the start of Work.

3.10.5. Existing Utilities

3.10.5.1. The attention of the Contractor is directed to the likely presence of existing underground utilities and overhead utilities and poles located within the Work site. The Contractor is cautioned that some utilities may not be catalogued on College or utility service provider record documents. Further, due to depth and/or types of materials used, some utilities may not be identifiable using traditional utility service locating methods.

3.10.5.2. Where any underground services are expected to be encountered during construction, prior to the start of work, the Contractor shall:

- (1) Review College record documents pertaining to affected underground services.
- (2) Interview Campus Facilities office with regard to affected underground services.
- (3) Call "Miss Utility" at least 48 hours in advance of construction for marking of public utilities.
- (4) Be responsible for costs and coordination of utility locator services necessary to locate and mark any private utility services within the Work site, whether or not indicated on record or Contract Documents.
- (5) Notify the College's Project Manager, Campus Facilities office, electric utility company, natural gas supplier, providers of communications, and any affected utility or other organization with a right-of way in or immediately adjacent to the Work area at least one week prior to starting work in the areas in which services are located and cooperate with any organization who elects to have a representative present during the conduct of the Work.

3.10.5.3. The Contractor shall exercise special care not to damage or disturb the utility infrastructure in any way.

3.10.5.4. The Contractor shall carefully hand dig representative test pits across the full width of anticipated trenches to confirm utility locations and to reveal any unknown utility conditions for assessment prior to permitting use of mechanical excavation equipment.

3.10.5.5. All underground utility locations associated with the scope of Work, or revealed during the conduct of the Work, including the location, size and material of all water, sanitary sewer, storm sewer, gas, electric, telephone, data, fiber, cable television, duct banks, steam and chilled water utilities within the project area, shall be recorded by the Contractor's surveyor and referenced to a campus benchmark provided by the College, which is in Maryland State Plane NAD83(NSRS2007) horizontal datum; NAVD88 vertical datum.

Indicate rim and invert elevation of sanitary sewers, storm sewers and storm water management structures. For all sub-surface utility lines on the site, locate the first connection to the off-site system. The horizontal and vertical location of all subsurface utilities must be measured directly prior to backfill. Locations shall be recorded on project progress documents. Electronic record documentation, in AutoCAD format, is required at project close-out.

3.10.5.6. Contractor shall maintain utility paint marks and flags, showing utility location and depth, until work is complete and survey information is transferred to project progress documents.

3.10.5.7. Contractor shall notify the College's Project Manager and Campus Facilities Office when underground utilities are discovered that are not identified by prevailing industry standard marking methods (e.g. color-coded tape and trace wires for non-metallic utilities). Campus Facilities Office will coordinate proper marking of utilities prior to Contractor's completion of the Work.

3.10.5.8. In the event that utility service is damaged during the conduct of the Work, Contractor shall notify the College's Project Manager and Campus Facilities and Security Offices. Repair of damages resulting from Contractor's actions shall be the responsibility of the Contractor. Regardless of responsibility, Contractor shall immediately undertake necessary repairs, including conducting Work off-hours and/or on weekends, to ensure prompt restoration of service in order to minimize impact of unplanned utility outages on College operations.

3.10.6. Erosion Control

3.10.6.1. The Contractor shall incorporate all permanent erosion control features, where applicable, into the Work at the earliest practicable time and shall maintain them in proper condition during the course of the Contract.

3.10.6.2. Temporary measures shall be used to control conditions that develop prior to installation of permanent control features, or that are needed to temporarily control erosion resulting from normal construction practices. Temporary controls may include off site control measures where such Work is necessary as a direct result of Contractor's construction activity.

3.10.7. Tree and Plant Protection

3.10.7.1. Unless otherwise shown in the Contract Documents, the Contractor shall protect all trees and plants which are liable to injury by construction operations and/or site mobilization plan.

3.10.7.2. Trees may not be used for any attachment or anchorage. Tree root zones shall be protected from overburden from construction traffic or storage of materials.

3.10.8. Snow and Ice Removal

3.10.8.1. Contractor shall provide snow and ice removal from within the project site area and from

pedestrian or vehicular routes providing immediate access to or routing around the project site.

3.10.8.2. When the College is officially closed due to snow and ice conditions and the Contractor plans to work, it is the Contractor's responsibility to provide additional snow and ice removal, including removal beyond the site project limits, as necessary to provide access required by its Workers, Subcontractors and/or suppliers.

3.10.8.3. At all times, Contractor shall cooperate and coordinate his snow and ice removal activities with College's snow and ice removal activities.

3.10.9. Trash Removal: Salvage and Recycling

Unless otherwise indicated in the Contract Documents:

3.10.9.1. Salvage rights belong to the Contractor when the Project scope of Work includes demolition and removal of existing materials or equipment.

3.10.9.2. Contractor shall implement best recycling practices as part of its trash removal protocol, with particular attention to sorting and recycling corrugated cardboard packaging materials, wood pallets, paper products and metal products.

3.10.10. Project Signage

3.10.10.1. Contractor may place his identification signage for promotional purposes at the Project site, subject to review and approval by the College's Project Manager.

3.11 HAZARDOUS AND TOXIC SUBSTANCES

3.11.1. Hazardous and Toxic Substances

3.11.1.1. The Contractor shall comply with all applicable federal, state, bi-county and local laws, ordinances and regulations relating to hazardous and toxic substances, including such laws, ordinances and regulations pertaining to access to information about hazardous and toxic substances, in effect on the date of the Contract and as amended from time to time. The Contractor shall further comply with any special provisions or requirements, including more stringent provisions, mandated by any entity having jurisdiction, including but not limited to the Montgomery County Department of Environmental Protection.

3.11.1.2. At least ten (10) calendar days prior to commencing any on-site Work required by these Contract Documents, the Contractor shall compile, maintain and submit to the College's Project Manager a "Chemical Information List" which shall contain the following information for each hazardous and toxic substance used, manufactured, processed, formulated, packaged, repackaged, handled, reacted, transferred, or stored at the job site: the common name, the chemical name, and identification of the Work area in which the hazardous chemical is found. A copy of this list shall be posted at all times at the Contractor's on-site project office. This list shall be updated and maintained in a current status by the Contractor as to the hazardous and toxic substance used, manufactured, processed, formulated, packaged, repackaged, handled, reacted, transferred or stored at the job site. The Contractor shall submit to the College's Project Manager an updated Chemical Information List at least 48-hours prior to the introduction of any additional hazardous and toxic substance not listed on the current Chemical Information List which is to be used, manufactured, processed, formulated, packaged, repackaged, handled, reacted, transferred or stored at the job site.

3.11.1.3. The Contractor shall provide the College's Project Manager at least 48-hours prior to commencing Work requiring the use of a hazardous and toxic substance with a "Material Safety Data

Sheet" or, in the case of a controlled hazardous waste substance, a hazardous waste manifest, for each hazardous and toxic substance listed or subsequently added to the Chemical Information List in compliance with applicable laws, ordinances and regulations.

3.11.2. Asbestos-Containing Materials

3.11.2.1. The Contractor shall not use, install, or apply any asbestos-containing building materials on any Work. Any exception to this requirement must be requested in writing by the Contractor with an explanation of Work requirements. The College will review any such request and must approve in writing the use of any asbestos-containing building materials on any Work prior to use, installation or application. Upon completion of the Project and before final acceptance is issued by the College, the Contractor shall provide the College's Project Manager with written and notarized certification that it did not use, install or apply asbestos-containing materials.

3.11.3. Environmental Litigation

3.11.3.1. If the performance of all or any part of the Work is suspended, delayed or interrupted due to an order of a court of competent jurisdiction as a result of environmental litigation as defined below, or by the order of any state or federal agency or official enforcing applicable laws, such expense, delay or interruption shall be considered as if ordered by the College under Article 2, College's Right To Stop Or Suspend Work. If it is determined that the suspension, delay, or interruption is due wholly or in part to acts or omissions of the Contractor or breach or violation of the terms of this Contract or acts of the Contractor not required by this Contract, the Contractor shall be responsible for all additional costs and delays resulting from such acts or omissions. The term "environmental litigation" as used herein means a complaint filed in court alleging that the Work will have an adverse effect on the environment and that the College has not duly considered, either substantively or procedurally, the effect of the Work on the environment.

3.12. CUTTING AND PATCHING

3.12.1. The Contractor shall be responsible for any cutting, fitting, or patching, required to complete the Work or to make its parts fit together properly.

3.12.2. The Contractor shall not damage or endanger a portion of the Work or other construction of the College or separate contractors by cutting, patching or otherwise altering such construction, or by excavation. The Contractor shall not cut or otherwise alter such construction by the College or a separate contractor except with written consent of the College and of such separate contractor; such consent shall not be unreasonably withheld. The Contractor shall not unreasonably withhold from the College or a separate contractor the Contractor's consent to cutting or otherwise altering its Work.

3.13. CLEANING

3.13.1. Progress Cleaning

3.13.1.1. The Contractor shall keep the premises and surrounding area free from accumulation of waste materials or rubbish caused by operations under the Contract, and shall remove and dispose of waste materials or rubbish prior to the end of each working day.

3.13.1.2. If the Contractor fails to clean up as provided in the Contract Documents, the College's Project Manager may do so and the cost thereof shall be charged to the Contractor.

3.13.2. Final Cleaning

3.13.2.1. At completion of the Work the Contractor shall remove from and about the Work waste materials, rubbish, the Contractor's tools, construction equipment, machinery and surplus materials.

3.13.2.2. Contractor shall wet clean all floors and surfaces or otherwise clean any equipment and materials installed in accordance with manufacturer's instructions.

3.14. ROYALTIES, PATENTS AND LICENSE FEES

3.14.1. The Contractor assumes the risk that any materials, equipment, processes or other items required under the Contract or furnished by the Contractor are subject to any patent, copyright, mark, secret or other property right of another. The Contractor shall pay for all royalties and license fees and shall obtain all necessary licenses or permits to permit use of any such item by the College. Contractor shall defend all suits or claims of infringement of any patent, copyright, mark, secret or other property right of another and shall save the College harmless from loss or expense on account thereof.

3.14.2. When an item specified by the College or furnished by the Contractor infringes or is alleged to infringe any patent, copyright, mark, secret or other property right of another, the Contractor will, at its option, and at no additional cost to the College, (1) procure for the College the right to use the item; (2) replace the item with an approved, non-infringing equal; or (3) modify the item so that it becomes non-infringing and performs substantially the same as the original item.

3.14.3. The review by the College of any method of construction, invention, appliance, process, article, device or material of any kind shall be for its adequacy for the Work, and shall not be an approval of the use thereof by the Contractor in violation of any patent or other rights or any third person.

3.15. INDEMNIFICATION

3.15.1 The Contractor shall be responsible for any property damage, loss, personal injury, death and/or any other damage which may occur by reason of the Contractor's acts, negligence, willfulness or failure to perform any of the obligations required by this Agreement. The Contractor agrees to indemnify and save harmless the College and its respective employees, volunteers, students, and trustees, as applicable, (the "Indemnitees") from any claims, loss, costs, damages or other expenses suffered or incurred by the Indemnitees, including attorney's fees and costs, by reason of the Contractor's acts, negligence, willfulness or failure to perform any of the obligations required by this Agreement. The Contractor at its own expense shall defend the Indemnitees in any action or suit brought against any of the Indemnitees arising out of the Contractor's acts, negligence, willfulness or failure to perform any of the obligations required by this Agreement. Any acts, negligence, willfulness or failure to perform any of the obligations required by this Agreement on the part of any agent, servant, employee or Subcontractor of the Contractor, or any Subcontractor's agent, servant or employee, are deemed to be the Contractor's acts, negligence, willfulness or failure to perform any of the obligations defined by this Agreement.

3.15.2 In claims against any person or entity indemnified under subsection 3.15.1 by an employee of the Contractor, a Subcontractor, anyone directly or indirectly employed by them, or anyone for whose acts they may be liable, the indemnification obligation under subsection 3.15.1 shall not be limited by a limitation on the amount or type of damages, compensation or benefits payable by or for the Contractor or a Subcontractor under workers or workmen's compensation acts, disability benefit acts or other employee benefit acts.

3.15.3. The College may retain such moneys due or to become due the Contractor under this Agreement as it considers necessary until such suits or claims for damages have been settled or otherwise disposed of and satisfactory evidence to that effect has been furnished to the College.

3.15.4. The provisions of this Article shall survive the termination of the Agreement.

ARTICLE 4 – ADMINISTRATION OF THE CONTRACT

4.1. CLARIFYING INSTRUCTIONS

4.1.1. The College shall be the final interpreter of the Contract Documents. Through the College's Project Manager, the College will furnish, with reasonable promptness, such clarifications as it may deem necessary for the proper execution of the Work. Except as otherwise expressly provided in the Contract Documents, all recommendations by the Architect/Engineer and/or College's Project Manager with cost or schedule ramifications are subject to approval by the College. The Work shall be executed in conformity therewith and the Contractor shall do no Work without proper drawings and instructions. The Architect/Engineer and/or College's Project Manager have no authority to waive or change the requirements of the Contract Documents except to make minor changes in the Work which do not result in a claim for extra cost or time, and which are consistent with the intent of the Contract Documents.

4.1.2. Wherever typical parts or sections of the Work are completely detailed on the drawings and other parts or sections which are essentially of the same construction are shown in outline only, the complete details shall apply to the Work which is shown in outline.

4.1.3. Dimensions of Work shall not be determined by scale or rule. Figured dimensions shall be followed at all times. If figured dimensions are lacking on drawings, the Architect/Engineer shall supply them on request to the Contractor.

4.2. REQUESTS FOR INFORMATION

4.2.1. In the event that the Contractor requires clarifications on or discovers conflicts or discrepancies in the Contract Documents, the Contractor shall submit a "Request for Information", in a format suitable to the College's Project Manager and Architect/Engineer prior to proceeding with the Work.

4.2.2. Unless otherwise indicated in the Contract Documents, the Contractor shall prepare and routinely update an RFI log indicating the status of RFIs.

4.2.3. The Contractor must allow the Architect/Engineer, College's Project Manager and the College a reasonable time following receipt of each RFI to review the documents and respond to the Contractor. To the extent that additional time for review is needed to clarify the information submitted by the Contractor or its Subcontractors and suppliers, the Contractor will be notified of the cause of the delay and advised of how long it will take to complete the review; provided, however, that mere failure to give the Contractor such notice shall not entitle the Contractor to make a claim for additional compensation or a time extension. The Architect/Engineer will return the completed RFI response to the Contractor and also provide one copy each to the College and College's Project Manager.

4.2.4. The Contractor shall perform no portion of the Work requiring RFI response until the respective RFI response has been issued by the Architect/Engineer. Work performed without a response shall be at the Contractor's risk.

4.2.5. Should the Contractor consider any RFI response to cause a change in the scope of the Work from that required by the Contract Documents, whether or not such change may affect contract price or time, then the Contractor shall desist from further action relative to the item in question and shall in writing (1) immediately notify the Architect/Engineer, the College and College's Project Manager requesting clarification; and (2) furnish them, within seven (7) days, with a notice explaining the nature of the change and whether increased or decreased cost and/or time is anticipated. No Work related to the RFI shall be executed until the entire matter is clarified and the Contractor is ordered by the College to proceed. Failure of the Contractor to serve written notice as required herein shall constitute a waiver of any claim in relation thereto.

4.3. SITE VISITS AND OBSERVATIONS

4.3.1. The College's Project Manager, and Architect/Engineer, shall at all times have access to the Work wherever it is in progress. The Contractor shall provide proper and safe facilities for such access and for

visits at the place of manufacture or elsewhere.

4.3.2. Inspections by the College's Project Manager, or Architect/Engineer, are for the sole benefit of the College. If the Contract Documents, the College Project Manager's, or Architect/Engineer's instructions, or laws, ordinances or any public authority require any Work to be specially tested or reviewed, the Contractor shall give the College's Project Manager timely notice of the Work's readiness for inspection. If the Work is scheduled to be inspected by an authority other than the College's Project Manager, and Architect/Engineer, the Contractor shall inform the College's Project Manager of the date fixed for such inspection. Required certificates of inspection shall be secured by the Contractor. Inspections by the College's Project Manager and Architect/Engineer shall be made promptly and where practicable, inspections may be made at the source of supply.

4.3.3. If any Work has been covered up contrary to the requirements of the Contract Documents or instructions of the College's Project Manager or Architect/Engineer before it has been observed, such Work must, if required by the College's Project Manager and/or Architect/Engineer, be uncovered for observation and replaced and/or recovered, at the Contractor's expense.

4.3.4. If any questioned Work has been covered up which is not required to be observed by the College's Project Manager and/or Architect/Engineer prior to being covered, the College's Project Manager and/or Architect/Engineer may request to see the Work in question and it shall be uncovered by the Contractor as directed. If such Work is found to be in accordance with the requirements of the Contract Documents, the College shall reimburse the Contractor for the cost of such uncovering and recovering. Such reimbursement shall be limited to the direct cost incurred plus the Contractor's approved percentage for overhead and profit. If the Work is found to be not in accordance with the requirements of the Contract Documents, the Contractor shall pay all costs associated with uncovering, correcting and recovering the Work.

4.3.5. The Contractor shall place its field engineers at the College's Project Manager's or Architect/Engineer's disposal for field checking during any inspection period. When layouts of the building and site work are to be made, the Contractor shall notify the College's Project Manager and Architect/Engineer in sufficient time so that the College's Project Manager and Architect/Engineer may be present.

4.3.6. Neither the presence nor the absence of the College's Project Manager or Architect/Engineer on the job shall relieve the Contractor from responsibility to comply with the provisions of the Contract Documents, nor from responsibility to remove and replace Work not in accordance therewith.

4.4. CLAIMS AND DISPUTES

4.4.1. Definition of Claim

4.4.1.1. A claim is a demand or assertion by one of the parties seeking, as a matter of right, adjustment or interpretation of Contract terms, payment of money, extension of time, or other relief with respect to the terms of the Contract. The term "claim" also includes other disputes and matters in question between the College and Contractor arising out of or relating to the Contract. Claims must be made by written notice. The responsibility to substantiate claims shall rest with the party making the claim.

4.4.2. Claims for Concealed or Unknown Conditions

4.4.2.1. If conditions are encountered at the site which are (1) subsurface or otherwise concealed physical conditions which differ materially from those indicated in the Contract Documents or (2) unknown physical conditions of an unusual nature which differ materially from those ordinarily found

to exist and generally recognized as inherent in construction activities of the character provided for in the Contract Documents, then the Contractor shall give notice to the College's Project Manager promptly before conditions are disturbed and in no event later than fifteen (15) calendar days after first

observance of the conditions. Upon receipt of such notice the College's Project Manager and Architect/Engineer will promptly investigate such conditions and if they differ materially and cause an increase or decrease in the Contractor's cost of, or time required for, performance of any part of the Work will determine an equitable adjustment in the Contract Sum or Contract time or both. No change in the Contract Sum or Contract time or both will be allowed except by formal approval of the College. If it is determined that the conditions at the site are not materially different from those indicated in the Contract Documents and that no change in the terms of the Contract is justified, the College's Project Manager shall so notify the Contractor in writing stating the reasons. Claims by Contractor which dispute such a determination must be made in accordance with subsection 4.4.5.

4.4.3. Claims for Extension of Time

4.4.3.1. If the Contractor is delayed at any time in the progress of the Work by any act or omission of the College, or its employees or by any other contractor employed by the College, or by changes ordered in the Work, or by strikes, lockouts, fire, unavoidable casualties, or any causes beyond the Contractor's control, or by delay authorized by the College pending a decision, or by any cause which the College shall decide to justify the delay, the time of completion shall be extended for such reasonable time as the College may decide.

4.4.3.2. The Contractor may be entitled to a time extension, but no additional compensation, if the delay in the completion of the Work arises from unforeseeable causes beyond the control and without the fault or negligence of the Contractor, including but not restricted to, acts of God, acts of the public enemy, acts of another contractor in the performance of a contract with the College, fires, floods, epidemics, quarantine restrictions, strikes, foreign embargoes, unusually severe weather, or delays of Subcontractors or suppliers arising from unforeseeable causes beyond the control and without the fault or negligence of both the Contractor and the Subcontractor or suppliers, the time of completion shall be extended for such reasonable time as the College may decide.

4.4.3.3. Claims for extension of time will be considered by the College only if made in writing to the College. Any claim for an extension of time must be made within seven (7) calendar days of the occurrence of conditions which in the opinion of the Contractor warrant such an extension. Failure to submit a claim for an extension of time within seven (7) calendar days shall constitute a waiver of Contractor's right to claim or receive a time extension. In the case of a continuing cause of delay, only one claim is necessary. Within thirty (30) days of filing a time extension claim notice, the Contractor shall submit a clear written statement and relevant supporting documentation substantiating the claim. The documentation shall include a revised schedule, which conforms to the schedules submitted each month with the payment requests and which shows the duration of the delay, its relation to other activities, and how the alleged delay was on the critical path. No time extension will be allowed except by formal approval of the College. The College with advice and assistance from the College's Project Manager shall ascertain the facts and the extent of the delay and extend the time for completing the Work, when in the College's judgment the findings of fact justify such an extension. The College's findings of fact shall be final and conclusive on the parties, subject only to appeal as provided in section 4.5 of this Contract.

4.4.4. Claims for Equitable Adjustment for Delay

4.4.4.1 If a delay in completion of the Work is caused by the College and compensation is not provided for under Changes in the Work otherwise negotiated, and the Contractor's Work is materially affected by that delay, then the Contractor may be entitled to submit a claim for an equitable adjustment in compensation.

4.4.4.2 Schedule management within the Contract duration established at time of Bid/Proposal, including decisions that may alter sequencing of all or part the Work, does not constitute grounds for an equitable adjustment for delay claim from Contractor or its subcontractors or vendors. All prices are firm for the duration of the overall Contract term.

4.4.4.3 Only the following items may be recoverable by the Contractor as compensation or damages for delay:

- (1) Direct costs, consisting of
 1. actual additional salaried and non-salaried on-site labor expenses;
 2. actual additional costs of materials;
 3. actual additional equipment costs, based solely on actual ownership costs of owned equipment or actual reasonable costs of rented or leased equipment;
 4. actual additional extended field office expenses, excluding those which are to be included in overhead;
 5. actual additional reasonable costs of Subcontractor and suppliers at any tier for which the Contractor is liable;
- (2) actual additional costs proven by clear and convincing evidence, resulting from labor or other inefficiencies but only if proven by clear and convincing evidence; and
- (3) an additional percentage for overhead and profit of 15% for actual additional Work performed by the Contractor's own forces and 5% for actual additional Work performed by a Subcontractor.

4.4.4.4. No claim under this subsection shall be allowed for any costs incurred more than twenty days before the Contractor shall have notified the College in writing of the delay.

4.4.4.5. No other compensation or damages are recoverable by Contractor for compensable delays or extensions of the completion time except as expressly stated herein. In particular, the College will not be liable for the following (by way of example and not of limitation) whether claimed by the Contractor or by a Subcontractor or supplier at any tier: (a) profit in excess of that provided herein; (b) loss of profit; (c) home office or other overhead in excess of that provided herein; (d) overhead calculated by use of the Eichleay formula or similar formulae; (e) consequential damages of any kind, including loss of additional bonding capacity, loss of bidding opportunities, and insolvency; (f) indirect costs or expenses of any nature except those expressly provided for herein; and (g) attorneys fees, costs of claims preparation and presentation, and costs of litigation.

4.4.4.6. There shall be deducted from the compensation payable to the Contractor under this section for delay any and all costs, expenses, and overhead recovered or recoverable by the Contractor under change orders issued to the Contractor or otherwise recovered or recoverable by the Contractor.

4.4.4.7. Contractor shall not be entitled to compensation or damages for delay unless, within seven (7) calendar days of the act, omission, occurrence, event or other factor alleged to have caused the delay, the Contractor notifies the College in writing of (a) the alleged delay and its anticipated duration; and (b) the act, omission, occurrence, event or other factor allegedly causing the delay. Knowledge on the part of the College or College's Project Manager of the act, omission, occurrence, event, or other factor or of the delay allegedly resulting there from, shall not excuse Contractor's failure to give the College the written notice required by this subsection.

4.4.5. Claims and Disputes Procedure

4.4.5.1. Unless a lesser period is prescribed by the Contract, the Contractor shall file a written notice of claim relating to the Contract, to the College's Project Manager within fifteen days after the basis of the claim is known or should have been known, whichever is earlier. Contemporaneously with, or within thirty days of filing of a notice of claim, but, as approved by College's Project Manager, no later than the date that final payment is made, the Contractor shall submit the claim to the College's Project Manager. The claim shall be in writing and shall contain:

- (1) an explanation of the claim, including references to all Contract provisions upon which it is based;
- (2) the amount of the claim;

- (3) the facts upon which the claim is based;
- (4) all pertinent data and correspondence that the Contractor relies upon to substantiate its claim. The Contractor shall submit such additional information as may be requested by the College's Project Manager; and
- (5) a certification by a senior official, officer or general partner of the Contractor or the Subcontractor, as applicable, that, to the best of the person's knowledge and belief, the claim is made in good faith, supporting data are accurate and complete, and the amount requested accurately reflects the Contract adjustment for which the person believes the College is liable.

4.4.5.2. A notice of claim or a claim that is not filed within the time prescribed by subsection 4.4.5.1 or a lesser period prescribed elsewhere in the Contract shall be dismissed and the claim shall be considered to be waived.

4.4.5.3. Upon receipt of the Contractor's claim, the College's Project Manager, shall take steps deemed necessary to review and investigate the claim. These steps may include an investigation and review of the facts pertinent to the claim, requesting additional information or substantiation from the Contractor or anyone else and taking such other steps as the College's Project Manager may consider appropriate.

4.4.5.4. Following their investigation, the College's Project Manager shall issue a written opinion regarding the claim, which shall contain such information as they consider appropriate.

4.4.5.5. Pending resolution of a claim, the Contractor shall proceed diligently with the performance of the Contract in accordance with the College's Project Manager's opinion, order, finding or interpretation. The Contractor shall take all reasonable action to mitigate or to avoid costs or damages for which the College may be liable. The College Project Manager's decision shall be final and conclusive unless the Contractor files a written appeal to the Vice President of Facilities & Public Safety within fifteen days of the date of the College's Project Manager's opinion. The Contractor shall include in its appeal all of the information which it wants considered in the appeal. The Vice President of Facilities & Public Safety, in consultation with such other persons as deemed advisable, shall prepare and deliver a written decision to the Contractor. The Vice Presidents' response shall be the College's final decision.

4.4.5.6. If the Contractor does not appeal the College's Project Manager's decision to the Vice President of Facilities & Public Safety within the time required under subsection 4.4.5.5, then the College's Project Manager's opinion shall be considered to be final, conclusive and binding upon the Contractor and College. There shall be no further right of review either administratively or in the courts. If the Contractor's timely appeals the College's Project Manager's decision to the Vice President of Facilities & Public Safety, the Vice President of Facilities & Public Safety's decision shall be considered to be conclusive and final unless within thirty days from the date of the Vice President of Facilities & Public Safety' decision the Contractor requests submitting the dispute to non-binding mediation as a condition precedent to commencing an action in the Circuit Court for Montgomery County. If no action is commenced within thirty days after the date of the Vice President of Facilities & Public Safety's decision, the Vice President of Facilities & Public Safety's decision shall be considered to be final, conclusive and binding on the Contractor and the College and the Contractor's right to appeal to the courts shall be waived.

4.4.5.7. If a court action is contemplated, all claims, disputes and other matters in question arising out of or related to the Contract or breach thereof shall first be submitted to non-binding mediation. Such mediation shall be in the nature of settlement discussions and privileged. The location of the mediation shall be in Rockville, Maryland.

4.4.5.8. The timely filing of a claim and the receipt of an opinion by the Contractor from the College's Project Manager, receipt of a decision from the College's Vice President of Facilities & Public Safety

and pursuit of non-binding mediation are conditions precedent to filing an action in court. Any action which may be commenced against the College shall be filed in the appropriate state court in Montgomery County, Maryland. The Contract and disputes arising out of it shall be governed by the laws of the State of Maryland without regard to conflicts of laws provisions.

4.4.5.9. Claims by the College against the Contractor may be commenced at any time in any appropriate court without regard to the other provisions of the Contract Documents, including subsection 4.4. This right is in addition to all other rights which the College may have under the Contract Documents.

4.5. DELAYS AND DAMAGES

4.5.1. No Waiver of Delay

4.5.1.1. Except as may be expressly agreed otherwise by the College in writing, no action or inaction by the College or its Project Managers shall constitute a grant of an extension of the completion date or the waiver of a delay or other default by the Contractor, including: (1) schedule, a recovery schedule, or an anticipated completion date from Contractor; (2) allowance, approval or acceptance of any schedule; (3) failure to terminate for default at an earlier date; or (4) demand that the Contractor finish the project by the required completion date or by any subsequent date promised by the Contractor.

4.5.2. Mitigation of Delays and College Remedies.

4.5.2.1. If Contractor should at any time cause interference, stoppage or delay to the Project or any activity necessary to complete the Project by the time required by this Contract (collectively, "Delay"), Contractor shall take all reasonable action to avoid or mitigate the effects the Delays, including but not limited to: (1) rescheduling or re-sequencing the Work and (2) re-assigning personnel. When the Contractor is responsible for any Delay, the College may order the Contractor to accelerate construction, work overtime, add additional shifts or manpower, work on weekends, or to do anything else reasonably necessary in order to finish on time, at no additional cost to the College. The Contractor does not have the unilateral right to complete the Work late and pay liquidated or other damages.

4.5.2.2 If Contractor should at any time cause the Delays described in subsection 4.5.2.1, then in addition to any other remedies the College may have under the Contract, the College, after notifying Contractor that it has forty-eight (48) hours within which to cure the Delay, may attempt to remedy the Delay by whatever means the College may deem necessary or appropriate including, but not limited to, correcting, furnishing, performing or otherwise completing the Work, or any part thereof by itself or through others, (utilizing where appropriate, any materials and equipment previously purchased for that purpose by Contractor), or by supplementing the Contractor's forces. The Contractor shall be liable to the College for all costs incurred by the College in attempting to remedy the Delay. The College may deduct the cost to remedy the Delay from any monies due or to become due to the Contractor.

4.5.3. Severe Weather Delays

4.5.3.1. "Unusually severe weather" is weather which is more severe than the historical average for the month as evidenced by the National Weather Service for the locality of the Work. Time extensions for unusually severe weather will be allowed on a tentative basis only and the final decision will be reserved until the Work is substantially completed. Weather conditions prevailing throughout the entire Contract period will be considered, including consideration for abnormally mild conditions to offset abnormally severe conditions. Extension of time due to abnormal weather conditions will be granted

on the basis of one (1) calendar day for each normal working day lost, or as mutually agreed upon by

the College and the Contractor. No additional compensation will be provided to the Contractor.

4.5.3.2. The College and the Contractor shall use the following table labeled “Monthly Anticipated Adverse Weather Days 9in work days)” as the basis for determining the anticipated number of “unusually severe weather” workdays at the construction site:

Monthly Anticipated Adverse Weather Days (in work days)											
JAN	FEB	MAR	APR	MAY	JUN	JUL	AUG	SEP	OCT	NOV	DEC
4	5	4	5	5	3	3	3	2	4	4	4

A lost work day shall be considered a weather delay when unusually severe weather exists and when such weather conditions directly cause work to be delayed on the activity or activities which are on the critical path according to the latest accepted update of the schedule during that month. Weather-caused schedule losses shall be measured in half (0.5) workday increments if the unusually severe weather affects work at the site only for one half of a normal workday. If unusually severe weather occurs during the first half of a normal work and also delays work during the second half of the day (e.g., due to employees not being required to report to work due to unusually severe weather), the entire work day shall be considered a weather caused lost work day. The Contractor’s request for weather caused time extensions during a given month shall be considered only for actual work days lost in excess of the number of work days listed in the table above and meeting the above criteria. The Contractor shall meet the submission and notification requirements and follow the procedures for requesting time adjustments to the schedule as described in Section 4.4.3.

4.5.4. Liquidated Damages

4.5.4.1. It is agreed that time is of the essence and therefore the College will suffer substantial damages if the Work is not completed within the time stated in the Preliminary Project Schedule contained in the Contract Documents. For each day that the Work shall be uncompleted after the date set for Substantial Completion, the Contractor may be liable for liquidated damages in the amount specified in the Contract Documents. Prior to and after expiration of the Contract completion time, the College may withhold an amount equal to liquidated damages whenever the progress of construction is such that, due to the fault or responsibility of the Contractor, the Contractor, in the judgment of the College is behind schedule so as not reasonably to be able to permit completion of the Project on time. Due account shall be taken of excusable delays, any extensions of time reasonably due the Contractor for completion of additional Work under change orders, and for delays for which the College is responsible, provided that the Contractor has properly requested time extensions therefore. After submission of a price, the Contractor may not contest the reasonableness of the amount of liquidated damages stated in the Contract. These assessed damages shall not be considered as a penalty, but as mutually agreed upon as the ascertained damages suffered by the College because of the delay.

4.5.5. Waiver of Consequential Damages

4.5.5.1 The Contractor waives claims against the College for consequential damages arising out of or relating to this Contract. The waiver includes but is not limited to damages incurred by the Contractor for principal office expenses including the compensation of personnel stationed there, for losses of financing, business and reputation, and for loss of profit of any type.

This waiver is applicable, without limitation, to all consequential damages due to Contractor in accordance with Article 12 of this Contract.

ARTICLE 5 – CONSTRUCTION BY COLLEGE OR BY SEPARATE CONTRACTORS

5.1 SEPARATE CONTRACTS

5.1.1. The College reserves the right to let other contracts in connection with the Project. The Contractor

shall afford other contractors reasonable opportunity for the introduction and storage of their materials and for the execution of their work, and shall properly connect and coordinate its Work with theirs. The Contractor shall work harmoniously with other contractors. The Contractor is not entitled to overhead, profit, or other compensation for work done for the College by other contractors.

5.1.2. If any part of the Contractor's Work depends on the proper execution or completion of any other contractor's work, the Contractor shall inspect and measure the work of the other contractor(s) and promptly report to the College's Project Manager any defects or discrepancies in such work. The Contractor's failure to inspect and make such a report shall constitute an acceptance of the other contractor's work as fit and proper for the proper execution of its Work, except as to latent defects.

5.1.3. The College's Project Manager will schedule and coordinate the Work of the Contractor with the work of all separate contractors on the Project including use of the site by the Contractor and the separate contractors. The College's Project Manager will keep the Contractor informed of the progress schedule to enable the Contractor to reasonably plan and perform its Work properly. The College's Project Manager may issue appropriate directions and require the Contractor to take such other measures as may be necessary to timely coordinate and progress the Work. Any neglect or refusal by the Contractor to comply with directions issued by the College's Project Manager shall constitute a failure to perform the Work in accordance with the Contract requirements and will justify action from withholding of payments otherwise due up to and including termination of the Contract.

5.1.4. The College and College's Project Manager do not guarantee the unimpeded operations of the Contractor. The Contractor acknowledges that the award of more than one contract for a Project necessitates the proper scheduling and sequencing of the Work with the work of all other contractors, and may lead to inherent delays in the progress of the Work. The Contractor agrees to re-sequence its Work as may be reasonably directed by the College's Project Manager from time to time. The Contractor hereby agrees to make no claim for delays caused by the presence or operations of other contractors engaged on the Project.

5.1.5. Should the Contractor sustain any damage through any act or omission of any other contractor having a contract with the College for the performance of work on the Project, or through any act or omission of a subcontractor of such other contractor, the Contractor shall make no claim against the College or its consultants (including but not limited to the Architect/Engineer and College's Project Manager) for such damage, but shall have a right to recover such damage from the other contractor under a provision similar to subparagraph 5.1.6 which has been or will be inserted in all contracts with such other contractors. The Contractor hereby releases the College, College's Project Manager and Architect/Engineer and their respective officers and employees from all damages to the Contractor caused by other contractors on the Project.

5.1.6. Should any other contractor under contract with the College for performance of work on the Project sustain any damage through any act or omission of the Contractor hereunder, or through any act or omission of a Contractor's subcontractor of any tier, the Contractor agrees to reimburse such other contractor for all such damages and to indemnify and hold the College, College's Project Manager and Architect/Engineer harmless from all such claims, including attorneys' fees, to the fullest extent permitted by law.

5.1.7. The Contractor agrees that in the event of a dispute as to cooperation or coordination with other contractors on the Project, the College's Project Manager will act as mediator and decisions made by the College's Project Manager will be binding.

5.1.8. The Contractor shall fully cooperate and coordinate its Work with other contractors working on separate projects for other buildings, road work, and the like in accordance with College's Project Manager's direction.

5.1.9. Wherever work being done by any contractors or subcontractors is contiguous to Work covered by

the Contract Documents, the respective rights of the parties shall be established by the College's Project Manager to secure the completion of the various portions of the Work in general harmony.

5.1.10. If a dispute arises among the Contractor and other contractors as to the responsibility under their respective contracts for maintaining the premises and surrounding area free from waste materials and rubbish as described in these General Conditions, the College's Project Manager may direct who shall perform the cleanup. The College's Project Manager reserves the right to clean up and allocate the cost in a timely manner among those responsible as the College's Project Manager determines to be just.

ARTICLE 6 – CHANGES IN THE WORK

6.1. CHANGES IN THE WORK

6.1.1. Changes

6.1.1.1. The College unilaterally may, at any time, without notice to the sureties, if any, and without invalidating the Contract Documents, by written order designated or indicated to be an order, make any change in the Work including but not limited to changes in the Specifications, Drawings in the method or manner of performance of the Work, the College-furnished facilities, equipment, materials, services, or site or directing acceleration in the performance of the Work. Any other written order or an oral order, including a direction, instruction, interpretation, or determination from the College that causes or constitutes any such change shall be treated as a change order under this section provided that before performing the Work directed by the change that the Contractor gives the College's Project Manager written notice stating the date, circumstances and source of the order and that the Contractor regards the order as a change order. The Contractor shall not proceed to perform the Work described in the written or oral order unless the College's Project Manager acknowledges in writing to the Contractor that the order is a change order and that the Contractor is to proceed with the Work as a change.

6.1.1.2. If any change under this subsection causes an increase or decrease in the Contractor's cost of, or the time required for, the performance of any part of the Work under the Contract, whether or not changed by an order, an equitable adjustment shall be made and the Contract modified in writing accordingly; provided, however, except for claims based on defective Specifications or Drawings, that no claim for any order under subsection 6.1.1.1 above shall be allowed for any cost incurred more than twenty days before the Contractor gives written notice as therein required. In the case of defective Specifications or Drawings for which the College is responsible, the equitable adjustment shall include any increased costs reasonably incurred by the Contractor in attempting to comply with such defective Specifications or Drawings. The Contractor shall submit to the College Project Manager within ten (10) days after every ninety (90) days from the order to proceed with the Work a detailed list of all costs incurred attempting to comply with defective Specifications or Drawings during the immediately preceding ninety (90) day period until the effect of the defects are overcome. Costs included more than ninety (90) days old in a detailed list of costs are waived and will not be paid.

6.1.1.3. If the Contractor intends to assert a claim for an equitable adjustment under subsection 6.1.1, it shall, within thirty days after receipt of an order for the furnishing of written notice under subsection 6.1.1.1 submit to the College's Project Manager a written statement setting forth the general nature of the monetary extent of the claim.

6.1.2. Disputed Work

6.1.2.1. In the event of a dispute between the College and the Contractor as to whether any Work is included in the scope of the Contract, such that the Contractor will be obligated to provide that Work

at no additional cost to the College, the College's Project Manager may order the Contractor in writing under this section to perform the Work. If the Contractor considers such an order to be a change in the scope of the Contract entitling the Contractor to additional compensation, a time extension, or other relief, the Contractor must provide notice within seven days (7) from receipt of the College's Project Manager's written order under the section to perform the Work and to initiate a claim therefore in accordance with Contract requirements.

6.1.2.2. A request by the Contractor for additional time or additional costs caused by the impact of an order of the College on the critical path for completion must be accompanied by (a) a reasonably detailed description of the effect of the order on the adjusted critical path and (b) supporting documentation. The mere existence of a change order does not entitle the Contractor to an extension of time, compensation for delay or damages or costs associated with delay. Contractor's entitlement thereto shall depend upon the effect of the change order on the adjusted critical path for completion and shall be subject to the requirements of Article 3.7, Prosecution and Progress of the Work.

6.1.2.3. Upon receipt of a signed written order of the College's Project Manager under this subsection, the Contractor shall comply with the order promptly, within the requirements of the completion schedule, whether or not the Contractor signs or accepts the change order. Failure to comply with the order in a timely manner shall constitute a breach of the Contract and grounds for termination for default or any other remedy available to the College.

6.1.3. Modification of Contract Sum

6.1.3.1. When changes in the Work may require a modification of the Contract Sum, the Contractor shall provide to the College's Project Manager, within thirty (30) days of its receipt of a proposal request, an itemized breakdown showing quantities, unit costs, hours and rates of labor, and other costs in such detail as may be required to allow the reasonableness of the cost to be established. Similar cost information covering Subcontractor's Work shall be included as part of the Contractor's proposal. Minimum charges for "handling" will not be acceptable. Charges for general supervision and management will not be acceptable.

6.1.3.2. Modification of the Contract Sum, when required, shall be determined as follows:

- (1) When applicable unit prices are stated in the Contract or have been subsequently agreed upon, by application of such unit prices.
- (2) A lump sum price agreed upon by the College and the Contractor.
- (3) If job conditions or circumstances or the extent or nature of the change, or failure of the College and the Contractor to agree upon a lump sum price or the application of unit prices, prevent the determination of the cost of any proposed change, the Work shall be paid pursuant to subsection 6.1.3.4.
- (4) If a change involves a credit to the College, unless the amount must be determined by the application of unit prices, the amount of the credit shall be the greater of (a) the alternate or other itemized price for such Work stated in Contractor's price or (b) a reasonable price, including profit and overhead.
- (5) If the change involves both a credit and a debit, the sums shall be shown and the two sums balanced to determine the adjusted total cost or credit.
- (6) The mark up allowable to the Contractor for combined overhead and profit for Work performed solely by the Contractor with its own forces shall be a reasonable amount, but not to exceed 15% of the Contractor's costs (excluding items includable in overhead).
- (7) The mark up allowable to a Subcontractor for combined overhead and profit for Work performed solely with its own forces shall be a reasonable amount, but not to exceed 15% of the Subcontractor's cost of labor and materials and equipment. Mark ups for Sub-subcontractors or suppliers, if required, must be provided from within the markup allowance provided to the Subcontractor. No additional markup allowance will be allowed for Sub-subcontractors or suppliers. For Work performed by a Subcontractor solely with its own forces, the Contractor is entitled to a reasonable mark up for combined overhead

and profit, but not to exceed 5% of the Subcontractor's labor, materials and equipment cost.

Sample Maximum Mark-Up Calculation:

A.	Subcontractor's cost (LME) <i>(includes direct costs of Subsubcontractors and/or suppliers)</i>	= A
B.	Subcontractor's combined OH&P	= 15% of A
C.	Subcontractor's Bonds and Builder's Risk Insurance if required	= as a % of A+B
D.	Contractor's combined OH&P	= 5% of A
E.	Contractor's Bonds and Builder's Risk Insurance if required	= as a % of A+B+C+D
F.	Total Maximum Modification of Contract Sum:	= A+B+C+D+E

- (8) The Contractor shall be allowed the actual, reasonable additional cost for rental of machine power tools or special equipment, including fuel and lubricants which are necessary to execute the Work required on the change, but no percentage shall be added to this cost.
- (9) The Contractor and separately bonded subcontractors, if any, shall be allowed the actual, reasonable additional cost for Bonds and Builder's Risk Insurance, if required.

6.1.3.3. The allowable percentages for cost and overhead and profit as provided in subsections 6.1.3.2 (6) and (7) and elsewhere are deemed to include but not be limited to all costs and expenses of the following kinds: project management, supervision and coordination; job supervision and field office expenses required by the Contract; expenses for supervisors, superintendents, managers, timekeepers, clerks and watchmen; cost of correspondence of any kind; insurance not specifically mentioned herein; all expenses in connection with the maintenance and operation of the field office, use of small tools, cost of vehicles generally used for transporting either Workers, materials, tools or equipment to job location and incidental job burdens; and all expenses or maintenance for operation of Contractor's regularly established principle office, branch office, similar facilities and all other costs and expenses customarily classified as overhead or general conditions. The Contractor's entitlement to compensation or additional time for delays for which the College is responsible or for which an extension is due to the Contractor is also subject to section 4.5.

6.1.3.4. If the Contractor does not respond promptly or disagrees with the method for adjustment in the Contract Sum, the method and the adjustment shall be determined by the College on the basis of reasonable expenditures and savings of those performing the Work attributable to the change, including in case of an increase in the Contract Sum, a reasonable allowance for overhead and profit as stated in subsection 6.1.3.2 (6) and (7). In such a case, the Contractor shall keep and present in such form as the College's Project Manager may prescribe an itemized accounting together with appropriate supporting data. The itemized accounting shall be prepared daily and presented to the College's Project Manager at the conclusion of each day. Unless otherwise provided in the Contract Documents, reimbursable costs to the Contractor shall be limited to the following:

- (1) Costs of labor, including Social Security, old age and unemployment insurance, fringe benefits required by agreement or custom and Workers' compensation insurance;
- (2) Costs of materials, supplies and equipment, including cost of transportation, whether incorporated or consumed;
- (3) Rental costs of machinery and equipment exclusive of hand tools, whether rented from the Contractor or others; and
- (4) Cost of premiums for all bonds and insurance and permit fees related to the Work, provided that, the penal sum of the surety bond has been increased and the surety has increased the premium cost to the Contractor.
- (5) Pending final determination of the costs accumulated pursuant to subsection 6.1.3.4, amounts not in dispute may be included in an Application for Payment.

6.1.3.5. The College's Project Manager will review and make a recommendation regarding the adjustment in Contract Sum and/or Time proposed by the Contractor to the College. Only the College is authorized to approve adjustments in Contract Sum and/or Time. Approval by the College requires review and administrative processing, based on claim value, in accordance with the Board of Trustees Policy and Procedures, and the following schedule:

- Claims less than \$ 99,999 require review and approval by the College's Vice President for Facilities & Public Safety.
- Claims between \$ 100,000 and \$ 249,999 require review and approval by the College's Vice President for Administrative and Fiscal Services.
- Claims \$ 250,000 and greater require approval by the College's Board of Trustees as an action item at a monthly business meeting. Items requiring such approval must follow Board of Trustees agenda action item submission requirements. (Normally, action items are placed on the Board meeting agenda at least one month prior to the scheduled meeting date to allow time to conduct necessary internal administrative reviews prior to the Board meeting.)

6.1.4. Minor Changes in the Work

6.1.4.1. The College's Project Manager will have authority to order minor changes in the Work not involving adjustment in the Contract Sum or extension of the Contract time and not inconsistent with the intent of the Contract Documents. Such changes shall be effected by written order of the College's Project Manager and shall be binding on the College and Contractor. The Contractor shall carry out such written orders promptly.

ARTICLE 7 – PAYMENTS AND COMPLETION

7.1. SCHEDULE OF VALUES

7.1.1. To facilitate checking the Work performed, the Contractor shall furnish to the College's Project Manager a detailed Schedule of Values of the various parts of the Work, including quantities, aggregating to the Contract Sum. The schedule shall be divided so as to facilitate payments to Subcontractors, if any, made out in the form prescribed by the College's Project Manager, and, if required, supported by such evidence of its correctness as the College's Project Manager may direct. The Schedule of Values cost breakdown shall be used as a basis for Certificates of Payment unless it is found to be in error.

7.1.2. The Schedule of Values shall be submitted as soon as possible, but not less than fifteen (15) days prior to the first scheduled Application for Payment described in the General Conditions.

7.2. PROGRESS PAYMENTS

7.2.1. Application for Payment

7.2.1.1. No later than the 25th day of each month, the Contractor shall submit to the College's Project Manager an original and accurate Application for Payment dated the last day of the month in the form prescribed by the Contract Documents together with the supporting documentation listed herein. Applications for Payment received after the 25th day of each month, or not submitted on an original, or containing erroneous information, or missing the required supporting documentation, shall not be processed during that month's payment cycle. Payments shall be made on the value of Work expected to be completed up to and including the last day of the month based upon the labor and materials incorporated in the Work; and of materials suitably stored at the site; less the aggregate of any previous payments, retainages and amounts withheld under subsection 7.2.1.9. The Applications for Payment, including final payment, shall be reviewed and certified by the College's Project Manager. After reviewing and certifying the amounts due the Contractor, the College's Project Manager will

submit the Project Application and the Project Certificate for Payment, along with the Contractor's Applications and Certificates for Payment, to the Architect/Engineer. Based on the Architect/Engineer's observations and valuations of Contractor's Applications for Payment, and the Certifications of the College's Project Manager, the Architect/Engineer will review and certify the amounts due the Contractor and will issue a Project Certificate for Payment.

- (1) The Contractor shall promptly pay each Subcontractor, if any, upon receipt of payment from the Owner, out of the amount paid to the Contractor on account of such Subcontractor's Work, the amount to which each Subcontractor is entitled, reflecting the percentage actually retained, if any, from payments to the Contractor on account of the Subcontractor's Work. The Contractor may not withhold from the Subcontractor any portion of the payment due to any cause unrelated to the Subcontractor's performance of the Work on the Project, notwithstanding any prior agreement between Contractor and Subcontractor to the contrary.

7.2.1.2. No later than the 25th day of each month, each Application for Payment shall be supported by the following documentation, each in a form prescribed by the College, or in the case no form is prescribed, on a form provided by the Contractor and approved by the College's Project Manager:

- (1) Updated schedule information of Contractor's progress to date, including assessment of progress compared to scheduled completion date.
- (2) Subcontractors' certificates, statements and affidavits showing that portions of the Work covered by the Application for Payment have been completed and material included therein have been and will be delivered.
- (3) Affidavit from Contractor and Subcontractor on forms prescribed by the College, stating respectively that their work force, subcontractors, vendors and material suppliers have been paid from the proceeds of the last Application for Payment, and will be paid from the current Application for Payment, and that there are no outstanding claims for payment.

7.2.1.3. That part of the payment which is requested on account of materials delivered and suitably stored at the site or other approved location but not incorporated in the Work shall, if required by the College's Project Manager, be conditioned upon submission by the Contractor of bills of sale or upon such other procedure as will establish the College's title to such material or otherwise adequately protect the College's interest as determined by the College's Project Manager, including applicable insurance coverage and cost of transportation to the Project site for those materials and equipment stored off the site.

7.2.1.4. Provided that the Contractor has furnished acceptable payment and performance security equal to 100% of the Contract Sum, from each Application for Payment the College shall withhold as retainage no more than 5% of the amount earned. Unless otherwise agreed to by the College in writing, the retainage withheld shall be paid within 120 days after satisfactory completion of the Contract or within 120 days after resolution of a dispute or contract claim concerning the satisfactory completion of the Contract, whichever is later. The College reserves the right to withhold from payments otherwise due the Contractor any amount that the College reasonably believes necessary to protect its interest, including, but not limited to, the College concluding in its sole judgment that the Work may not be completed by the date required by the Contract or the Work is otherwise not in conformance with the requirements of the Contract Documents. Following Substantial Completion of the Project, the College in its sole discretion, may authorize reduction of retainage withheld to an amount not less than two (2) times the College's Project Manager's estimate of the value of the Contractor's punch list items.

7.2.1.5. Application for Payment shall be in the format required by the Contract Documents and the College's Project Manager. The Application shall include an itemized breakdown of the various items of the Work based on the previously submitted Schedule of Values.

7.2.1.6. The provisions for payment, withholding, retainage and Certificates of Payments are solely for the benefit of the College, and no other party (including sureties of the Contractor) may assert any

claim for negligence or other action against the College, or anyone acting on behalf of the College for waiving or misapplying these provisions.

7.2.1.7. No Certificate issued nor payment made to the Contractor may be construed as an acceptance of the Work or be construed or relied upon as any indication that the labor or materials are in accordance with the Contract Documents or that the amounts paid or certified therefore represent the correct cost or value of the Work or that such amounts are in fact or law due the Contractor.

7.2.1.8. Any Application for Payment which is based on a pending claim for additional compensation may be certified by the College's Project Manager and the Architect/Engineer to the extent that it is determined that the payments yet to be made under the Contract and/or the retainage are sufficient to protect the College. Nothing herein shall be construed as requiring the College's Project Manager and Architect/Engineer to certify such applications or to release retainage. All certifications and payments, including those pursuant to a pending claim, shall be tentative and conditional.

7.2.1.9. In addition to the College's general right to withhold payment as set forth in subsection 7.2.1.4, the College may withhold payment or, on account of subsequently discovered evidence, nullify or reduce the whole or part of any certificate or payment on account of:

- (1) failure to update schedules properly as required by subsection 3.7;
- (2) failure to furnish the documents required by subsection 7.2.1.1 and 7.2.1.2;
- (3) liquidated damages which may be assessed under the Contract Documents or other damages or compensation due the College for claims of the College against the Contractor;
- (4) the cost (measured by the contract value or fair market value whichever is greater) of completing unfinished or defective Work not remedied or deductions or amounts due the College under the Contract;
- (5) failure of the Contractor to perform any material Contract requirements;
- (6) claims filed or likely to be filed against the College for which the Contractor may be liable to the College;
- (7) failure of the Contractor to make payments properly to Subcontractors or suppliers for material or labor or amounts claimed by the Contractor's surety or insurer under any right of subrogation;
- (8) a reasonable doubt the Work can be completed for the residual balance of the Contract;
- (9) damage to another Contractor;
- (10) any claim of the College or debt owed to the College by the Contractor;
- (11) failure to maintain as-built drawings; or
- (12) the cost of completing unfinished warranty Work.

7.3. ACCEPTANCE OF THE WORK AND FINAL PAYMENT

7.3.1. Partial Acceptance

7.3.1.1. If, in its sole discretion, the College desires to occupy any portion of the Work, the College shall have the right to occupy and use those portions of the Work which in the opinion of the College can be used for their intended purpose; provided that the conditions of occupancy and use are established and the responsibilities for the Contractor and the College for maintenance, heat, light, utilities and insurance are mutually agreed to by the Contractor and the College. The College has no obligation to accept the Work in portions. Partial occupancy shall in no way relieve the Contractor of its responsibilities under the Contract.

7.3.1.2. When the College occupies the Work in portions or accepts the Work in portions, if the beneficial use of any accepted portion of the Work as a whole depends on Substantial Completion or beneficial use of any other portion, then, unless otherwise agreed to by the College in writing: (1) warranties on the accepted portions do not begin to run until substantial completion of all portions on

which beneficial use of the whole Work depends, and (2) Substantial Completion of the whole Work shall not be deemed to be achieved until Substantial Completion of all portions on which beneficial use of the whole depends.

7.3.2. Substantial Completion and Final Inspection

7.3.2.1. When the Work is substantially completed, the Contractor shall notify the College's Project Manager and Architect/Engineer in writing that the Work will be ready for final inspection and testing on a definite date. Reasonable notice shall be given by the Contractor to permit the College's Project Manager and Architect/Engineer to schedule the final inspection.

7.3.2.1.1 "Substantial Completion" is the stage in the progress of the Work when the Work or designated portion thereof is sufficiently complete in accordance with the Contract Documents so that the College can occupy or utilize the Work for its intended use.

7.3.2.2. The inspection shall be conducted by the College's Project Manager and the Architect/Engineer. On the basis of the inspection, if it is determined that the Work appears to be substantially complete and the Work appears to be ready for occupancy and usable for its intended purpose, the College's Project Manager and Architect/Engineer shall establish the date of Substantial Completion, shall fix the times at which the warranties will begin, and the Architect/Engineer shall issue a Certificate of Substantial Completion.

7.3.2.3. If it is determined that Substantial Completion has been achieved, the College's Project Manager shall fix the time within which the Contractor shall complete any remaining items of Work which will be indicated on a list (the "punch list"). If the Contractor fails to complete the remaining items so listed in the time stipulated, the College shall have the undisputed right to complete the Work at the Contractor's expense. The Contractor may be required to complete multiple punch lists until the Contract is performed in its entirety. Failure to complete punch list work in a timely manner shall constitute grounds for termination of the Contract for default. Final payment shall not be made until all Contract Work, including all punch list Work, is complete to the satisfaction of the College's Project Manager.

7.3.2.4. Acceptance of the Work as substantially complete shall not excuse or waive any failure of the Contractor to complete the Contract as required by the Contract Documents. The Work shall not be considered substantially complete until (1) all electrical, mechanical, and life safety systems shall be completed and successfully tested and successfully inspected for conformity to all requirements of the Contract Documents and all applicable codes and standards, (2) a certificate of occupancy has been obtained for all parts of the Work and (3) all other requirements for Substantial Completion are met.

7.3.2.5. Upon completion of the Work, the Contractor shall forward to the College's Project Manager a written notice that the Work is ready for final inspection and acceptance and shall also forward to the College's Project Manager a final Application for Payment. The final Application for Payment shall be processed in accordance with Subparagraph 7.3.3. Upon receipt, the College's Project Manager will forward the notice and Application to the Architect/Engineer who with the College's Project Manager will promptly make such inspection. When the Architect/Engineer, based on the recommendation of the College's Project Manager, finds the Work acceptable under the Contract Documents, the Architect/Engineer shall issue a Final Application and Certificate for Payment stating that the Work provided for in the Contract has been completed and is acceptable under the terms and conditions thereof and that the entire balance found to be due to the Contractor and noted in the final application is due and payable. The College's Project Manager and Architect/Engineer may not issue the Final Certificate and Application for Payment until all Work is fully completed and all other obligations of the Contractor under the Contract Documents have been completed.

7.3.3. Application for Final Payment

7.3.3.1. Upon completion of the Work, the Contractor shall prepare and submit to the College's Project Manager an Application for Final Payment. The College's Project Manager and Architect/Engineer will promptly proceed to make any necessary final surveys, to complete any necessary computations of quantities, and to complete other activities necessary to determine the Contractor's right to final payment. The College's Project Manager and Architect/Engineer will certify so much of the Contractor's Application for Final Payment as they consider due, The Contractor shall be informed of all deductions, damages, costs, back-charges, and other charges assessed against the Contractor by the College and the reasons therefore. Notwithstanding what is stated above, prior to or in the absence of a request from the Contractor for final payment, the College may determine the amount of the final payment it considers to be due to the Contractor.

7.3.3.2. If the Contractor disputes the amount determined by the College to be due it, it may initiate a claim under Article 4.4, Claims and Disputes.

7.3.3.3. Acceptance by the Contractor of any payment identified by the College as being a final payment shall operate as an accord and satisfaction and a general release of all claims of the Contractor against the College arising out of or connected with the Contract, except as may be expressly agreed otherwise in writing between the Contractor and the College. No claims by the Contractor may be asserted for the first time after the Contractor submits its Application for Final Payment or after final payment is made by the College.

7.3.3.4. Prior to final payment and before issuance of the College's Project Manager's and Architect/Engineer's final Certificates therefore, the Contractor shall fully comply with the following requirements:

- (1) Cleanup the Work area in accordance with the Specifications and federal, state, bi-county, county and local rules and regulations.
- (2) Provide a notarized affidavit stating that all monetary obligations to suppliers of material, services, labor and all Subcontractors have been completely fulfilled and discharged.
- (3) Complete all punch list Work and furnish to the College's Project Manager all documents, manuals and record (as-built) documents, including all BIM documents, if any.

7.4. ASSIGNMENT OF CONTRACT MONIES

7.4.1. The Contractor shall not assign any monies due to it under the Contract without the consent of the College, and the assignee in such case shall acquire no rights against the College.

7.5. AUDIT

7.5.1. If the Contractor has submitted any claim or request for additional payment exceeding \$50,000, or if the Contractor has submitted cost or pricing data in connection with the pricing of any modification to this Contract, the College shall have the right to examine and audit all books, records, documents, and other data of the Contractor (including computations and projections) related to negotiating, pricing or performing the modification or claim in order to evaluate the accuracy, completeness, and currency of the cost or pricing data. In addition to the above, the Contractor shall make available to the College the original project price estimate and backup takeoffs and records, and the actual monthly or periodic job cost records. If the Contractor fails or refuses to comply with applicable provisions concerning the Contract changes or claims, the College shall have no obligation to make payment to the Contractor for the change or claim.

7.5.2. The Contractor shall permit audit and fiscal and programmatic monitoring of the Work performed under this Contract. The Contractor shall make available at its office at all reasonable times, the materials described in subsection 7.5.1, for examination, audit or reproduction, for 3 years after final payment under the Contract.

7.5.3. If the Contract is completely or partially terminated, the records relating to the Work terminated shall be made available for 3 years after any resulting final termination settlement.

7.5.4. Records pertaining to claims, contract disputes, or to litigation or the settlement of claims arising under or relating to the performance of the Contract shall be made available until final disposition of such appeals, litigation, or claims.

ARTICLE 8 – PROTECTION OF PERSONS AND PROPERTY

8.1. SAFETY PRECAUTIONS AND PROGRAMS

8.1.1. The Contractor shall comply with all applicable laws, ordinances, rules, regulations and lawful orders of any public authority having jurisdiction for the safety of persons or property or to protect them from damage, injury or loss.

8.1.2. The Contractor shall be responsible for initiating, maintaining and supervising all safety precautions and programs in connection with the performance of the Contract. Contractor shall comply and cooperate with College safety and security programs.

8.1.3. Except as otherwise directed by the Contract Documents, in the event the Contractor encounters on the site material reasonably believed to be hazardous, including but not limited to asbestos or polychlorinated biphenyl (PCB), which has not been rendered harmless, the Contractor shall immediately stop Work in the area affected and report the condition to the College's Project Manager in writing. The Work in the affected area shall not thereafter be resumed except by written agreement of the College's Project Manager and Contractor if in fact the material is hazardous and has not been rendered harmless. The Work in the affected area shall be resumed in the absence of hazardous material.

8.2. PROTECTION OF PERSONS AND PROPERTY

8.2.1. The Contractor shall take all necessary precautions to ensure the safety of the public and of workers on the job, and to prevent accidents or injury to any persons on, about, or adjacent to the premises where the Work is being performed. The Contractor shall comply with the "Williams-Steiger Occupational Safety and Health Act of 1970, as amended, and all laws, ordinances, codes, rules and regulations relative to safety and the prevention of accidents, and shall also comply with the "Manual of Accident Prevention in Construction" of the Associated General Contractors of America and with the applicable provisions of the American Standard Safety Code for Building Construction, ANSI A 10 Series, unless prevention of accidents is regulated by a more stringent local, State or Federal code, ordinance or law. The Contractor shall erect and properly maintain at all times, as required by laws and regulations and the conditions and progress of the Work, proper safeguards, including minimum provision of six (6) foot fall protection, for the protection of Workers and the public and shall post signs and other warnings against the dangers created by openings, stairways, falling materials, open excavations and all other hazardous or unsafe conditions. It shall be the Contractor's exclusive responsibility to take all safety precautions which may be necessary to protect all persons and property from injury or damage.

8.2.2. Contractor shall request permission in writing of the College's Project Manager, and have received written permission from the College's Project Manager, prior to the storage, use, or transportation onto the campus of explosives or other hazardous materials or equipment required for the execution of the Work. The Contractor is prohibited from storing, using or transporting hazardous materials or equipment not required for the execution of the Work onto the campus. The Contractor shall exercise the utmost care and shall carry on such activities under the supervision of properly qualified personnel if such written permission has been granted.

8.2.3. All damage or loss to any property referred to in this section, caused in whole or in part by the Contractor, and Subcontractor, and sub-subcontractor, or anyone directly or indirectly employed by any of them or by anyone for whose acts any of them may be liable, shall be remedied by the Contractor, except damage or loss attributable solely due to faulty Drawings or Specifications or to the acts or omissions of the

College or Architect/Engineer or anyone employed by either of them or for whose acts either of them may be liable, and not also attributable to the fault or negligence of the Contractor.

8.2.4. The Contractor shall designate a responsible member of its organization at the site whose duty shall be the prevention of accidents. This person shall be the Contractor's superintendent unless otherwise designated in writing by the Contractor to the College's Project Manager.

8.2.5. Contractor shall not load or permit any part of the Work to be loaded so as to endanger its safety.

8.2.6. In any emergency affecting the safety of persons or property, the Contractor shall act, at the Contractor's discretion, to prevent threatened damage, injury or loss. Any additional compensation or extension of time claimed by the Contractor on account of emergency Work shall be determined as provided for in these General Conditions.

8.2.7. The Contractor shall continuously protect the Work and the College's property from damage, injury or loss arising in connection with operations under the Contract Documents. It shall make good any such damage, injury or loss, except such as may be caused solely by agents or employees of the College.

8.2.8. The Contractor shall be solely responsible for all damage due to intrusion and for the proper protection of the Project site from damage due to fire, rain, wind or other causes. The Contractor shall provide sufficient security personnel as it deems necessary for proper protection of the Work and project site at all times. The Contractor shall provide temporary protection to prevent unauthorized persons from obtaining access to the site during the night and at other non-working hours.

8.2.9. The Contractor shall assume sole financial responsibility for vandalism or loss of materials and equipment not covered by Contractor's Builder's Risk insurance.

8.2.10. The Contractor shall protect all streets, sidewalks, light poles, hydrants and concealed or exposed utilities of every description affected by or adjacent to the Work and if such items are damaged by the Contractor or Subcontractors, the Contractor shall make all necessary repairs thereto or replacements thereof at no cost to the College.

8.2.11. Tight wood sheathing or plywood shall be laid under any materials that are stored on finished cement surfaces.

8.2.12. The Contractor shall at all times provide and maintain adequate protection against weather so as to preserve all Work, materials, equipment, apparatus and fixtures free from injury or damage.

8.2.13. The Contractor shall provide and maintain adequate protection for all properties adjacent to the site. When required by law or for the safety of the Work, the Contractor shall shore up, brace, underpin and protect as necessary, foundations and other portions of existing structures which are in any way affected by the operations under the Contract Documents. The Contractor, before commencement of any part of the Work, shall give any notices required to be given to an adjoining landowner or other parties.

8.2.14. The Contractor shall confine its construction equipment, the storage of materials and the operations of workers to the limits indicated by laws, ordinances, permits and as may be established by the College, and shall not unreasonably encumber the premises with construction equipment or material.

8.2.15. The Contractor shall enforce the College's Project Manager's instructions regarding signs, advertisements, fires and smoking.

8.3. FIRE PROTECTION

8.3.1. Adequate precautions shall be taken against fire throughout all the Contractor's and Subcontractors'

operations. Flammable material shall be kept at an absolute minimum, and, if any, shall be properly handled and stored. Except as otherwise provided herein, the Contractor shall not permit fires to be built or open salamanders to be used in any part of the Work.

8.3.2. Construction practices, including cutting and welding, and protection during construction shall be in accordance with the published standards of the Industrial Risk Insurers and the National Fire Protection Association; provide a sufficient number of approved portable fire extinguishers, distributed about the project; and use non-freeze type in cold weather.

8.3.3. Gasoline and other flammable liquids shall be stored in and dispensed from Underwriters' Laboratories listed safety containers in conformance with the National Fire Protection Association recommendations. Storage of any flammable liquids, however, shall not be within buildings.

8.3.4. All tarpaulins that may be used for any purpose during construction of the Work shall be made of material which is resistant to fire, water and weather. All tarpaulins shall have the Underwriters' Laboratories approval and shall comply with FS CCC-D-746.

8.3.5. The Contractor shall maintain emergency and fire exits from the Work area, or establish alternative exits satisfactory to the Fire Marshal.

8.3.6. Fire protection and safety during the execution of the Work are the exclusive responsibility of the Contractor.

8.4. EMERGENCIES

8.4.1. In an emergency affecting the safety of life, the Work or adjoining property, the Contractor, without special instructions or authorization from the College's Project Manager, is permitted to act at the Contractor's discretion to prevent such threatened loss or injury. In such an emergency the Contractor shall act prudently and expeditiously to prevent any threatened loss or injury and shall immediately notify the College's Project Manager and the Campus Security Office of such actions.

8.5. ACCIDENTS

8.5.1. The Contractor shall provide at the site, and make available to all workers, medical supplies and equipment necessary to supply first aid service to all persons injured in connection with the Work.

8.5.2. Contractor must promptly report in writing to the College's Project Manager and the Campus Security Office all accidents arising out of, or in connection with, the performance of the Work, whether on or off the site, which caused death, personal injury or property damage, giving full details and statements of witnesses. In addition, if death or serious damages are caused, the accident shall be reported immediately by telephone or messenger. If any claim is made by anyone against the Contractor or any Subcontractor on account of any accident, the Contractor shall promptly report the facts in writing to the College's Project Manager and the Campus Security Office, giving full details of the claim.

ARTICLE 9 – INSURANCE AND BONDS

9.1. INSURANCE

9.1.1. Unless otherwise indicated in the Contract Documents, the Contractor shall maintain in force at all times during the term of this Agreement, with an insurance carrier licensed to do business in the State of Maryland acceptable to the College, the following minimum insurance coverage. This insurance must be kept

in full force and effect during the term of this contract, including all extensions. The insurance must be evidenced by a certificate of insurance, and if requested by the College, the proposed awardees/Contractor shall provide

a copy of the insurance policies. The Contractor's insurance shall be primary.

- a) Worker's Compensation Insurance covering the Contractor's employees as required by State of Maryland law with the following minimum limits:

Bodily Injury by Accident	\$ 100,000 each accident
Bodily Injury by Disease	\$ 500,000 policy limit
Bodily Injury by Disease	\$ 100,000 each employee.

- b) Commercial General Liability Insurance, excluding automobiles owned or hired by the Contractor, with limits as follows:

Bodily Injury and Property Damage:	\$ 10,000,000 combined single limit of bodily injury and property damage per occurrence
------------------------------------	---

- c) Comprehensive Automobile Liability Insurance, providing bodily injury and property damage coverage for owned vehicles, hired vehicles and non-owned vehicles with limits as follows:

Bodily Injury:	\$ 1,000,000 each person \$ 2,000,000 each occurrence
Property Damage:	\$ 2,000,000 each occurrence

- d) Builder's Risk Insurance, providing property damage and theft replacement coverage for goods provided and services rendered during construction. For building renovation projects, when custody of the building is turned over to the Contractor, the Builder's Risk policy must additionally include building replacement value.
- e) Insured - The College, its elected and appointed officials, officers, consultants, agents and employees must be named as an additional insured and loss payee on Contractor's Commercial and Excess/Umbrella Insurance for liability arising out of Contractor's products, goods and services provided under this Agreement.

9.1.2. Prior to the College signing the Contract, the Contractor shall provide the College with evidence of payment for the above insurance coverage. Any agreement for an extension of time to the Contract shall also include evidence of payment for extending the above insurance coverage for that agreed upon period of time.

9.1.3. These coverages and limits are to be considered minimum requirements under this Agreement and shall in no way limit the liability or obligations of the Contractor. The insurance shall provide that policy coverage will not be canceled, altered or materially changed without sixty (60) calendar days' prior notice to the College by registered or certified mail. The insurance shall not be limited to claims made only while the policy is in effect.

9.1.4. The Contractor shall furnish the College with a certificate of insurance as evidence of the required coverage. The certificates of insurance must name the College as an additional insured.

9.1.5. In the event that the Contractor's insurance is terminated, the Contractor shall immediately obtain other coverage and any lack of insurance shall be grounds for immediate termination of this Agreement.

9.1.6. For the purposes of this article, the word "licensed" shall be deemed to mean an insurance carrier either licensed or approved to do business in the State of Maryland.

9.2. PERFORMANCE, LABOR AND MATERIAL BONDS AND MAINTENANCE BOND

9.2.1. The College may require the Contractor to furnish bonds. The bonds furnished by the Contractor shall be issued by a surety licensed to conduct business in the State of Maryland. The surety shall be approved by the College. The bonds furnished shall comply in all respects with the requirements of Maryland's Little Miller Act and shall be in the form prescribed by the College.

9.2.2. Upon the request of any person or entity appearing to be a potential beneficiary of bonds covering payment of obligations arising under the Contract, the Contractor shall promptly furnish a copy of the bonds or shall permit a copy to be made.

9.2.3. If at any time, the surety becomes insolvent, files for bankruptcy or for any reason whatsoever loses its right to do business in the State of Maryland, the Contractor shall, as soon as practicable but no later than within five calendar days, inform the College of this occurrence in writing.

9.2.4. If at any time, the surety becomes insolvent, files for bankruptcy or for any reason whatsoever loses its right to do business in the State of Maryland, the Contractor shall, within ten (10) calendar days after notice from the College to do so, substitute an acceptable bond (or bonds) in such form and sum and signed by such other surety as may be satisfactory to the College.

ARTICLE 10 – CORRECTION OF WORK

10.1. CORRECTION OF WORK

10.1.1. Correction of Work Before Final Payment

10.1.1.1. The Contractor shall promptly remove from the premises all materials, equipment (whether incorporated in the Work or not) and Work rejected by the College's Project Manager as failing to conform to the Contract Documents, and the Contractor shall promptly replace and re-execute all Work under its Contract in accordance with the Contract Documents and without expense to the College and shall bear the expense of making good all Work of other contractors destroyed or damaged by such removal or replacement.

10.1.1.2. If the Contractor fails to correct nonconforming Work and does not proceed with correction of such Work within a reasonable period fixed by written notice from College's Project Manager, the College's Project Manager may remove it and store the salvable materials or equipment at the Contractor's expense. If the Contractor does not pay costs of such removal and storage within ten (10) calendar days after written notice, the College's Project Manager may upon ten (10) additional calendar days written notice sell such materials and equipment at auction or at private sale and shall account for the proceeds thereof, after deducting costs and damages that should have been borne by the Contractor, including compensation for the College's Project Manager's and Architect/Engineer's services and expenses made necessary thereby. If such proceeds of sale do not cover costs which the Contractor should have borne, the Contract sum shall be reduced by the deficiency. If payments then or thereafter due the Contractor are not sufficient to cover such amount, the Contractor shall pay the difference to the College.

10.1.2. Correction of Work after Substantial Completion of Work

10.1.2.1. If, within one year, or other time period established in the Contract Documents, after the date of Substantial Completion of the Work or designated portion thereof, any of the Work is found to not be in accordance with the Contract Documents, the Contractor, at its own expense shall correct it promptly after receipt of written notice from the College to do so. The Contractor shall pay for such tests and inspections made necessary by the faulty Work. The Contractor shall pay the costs incurred by the College for professional services and expenses, including but not limited to design professional and College's Project Manager fees, required as a result of Work found not in accordance with the

Contract Documents, during the correction period. The correction period shall be extended with respect to portions of Work first performed after Substantial Completion by the period of time between Substantial Completion and the actual performance of the Work. This obligation shall survive Final Completion of the Work under the Contract and the Contract Closeout.

10.2. ACCEPTANCE OF NON-CONFORMING WORK

10.2.1. If, in the opinion of the College, it is undesirable to replace any defective or damaged materials or to reconstruct or correct any portion of the Work injured or not performed in accordance with the Contract Documents, the compensation to be paid to the Contractor hereunder shall be reduced by such amount as in the judgment of the College to be equitable. Such adjustment shall be effected whether or not final payment has been made.

ARTICLE 11 – MISCELLANEOUS PROVISIONS

11.1. LEGAL OBLIGATIONS, RELATIONS AND RESPONSIBILITIES

11.1.1. Laws to be Observed

11.1.1.1. The Contractor shall keep fully informed of all Executive Orders, Federal, State, county, bi-county, regional and local laws, ordinances, rules and regulations and all orders and decrees of bodies of tribunals having any jurisdiction or authority, which in any matter affect those engaged or employed on the Work, or which in any way effect the conduct of the Work. It shall at all times observe and comply with all such laws, rules, ordinances, regulations, orders and decrees; it shall protect and indemnify the College and its Project Managers against any such claim or liability arising from or based on the violation of any law, ordinance, regulation, order, or decree, whether by itself or its employees, Subcontractors or suppliers at any tier. Whenever the Contract Documents require the Contractor to comply with provisions of Federal, State or local laws, regulations, ordinances or codes, the Contractor must comply whether such laws, regulations, ordinances or codes are expressly incorporated into the Contract or not.

11.1.1.2. The Contractor must comply with the provisions of the Workers' Compensation Act and Federal, State and local laws relating to hours of labor.

11.1.1.3. This Contract shall be construed and interpreted according to the laws of the State of Maryland, without regard to principles of conflicts of law.

11.1.1.4. If the Contractor observes that the Contract Documents are at variance with any applicable law, ordinance or regulation, it shall promptly notify the College's Project Manager, and any necessary change shall be adjusted as provided in the Contract for changes in the Work. If the Contractor performs any Work knowing it to be contrary to such laws, ordinances, rules and regulations, and without such notice, it shall bear all costs arising therefrom.

11.1.2. Regulations

11.1.2.1. Wherever any provision of any section of the Specifications conflicts with any agreements or regulations of any kind at any time in force among members of any Associations, Unions or Councils, which regulate or distinguish what work shall or shall not be included in the work of any particular, the Contractor shall make all necessary arrangements to reconcile any such conflict without delay, damage or cost to the College and without recourse to the College.

11.1.2.2. In case the progress of the Work is affected by any undue delay in furnishing or installing any items of material or equipment required under the Contract because of a conflict involving any

such agreement or regulation, the College's Project Manager and Architect/Engineer may require that other material or equipment of equal kind and quality be provided at no additional cost to the College.

11.2. INDEPENDENT CONTRACTOR

11.2.1. The Contractor shall perform the Contract as an independent contractor and shall not be considered as an agent of the College, nor shall any employee or agent of the Contractor be considered subagents of the College. Nothing in this Contract shall be construed as constituting a partnership, joint venture, or agency between the College and Contractor. Other than duties of the College's Project Manager based on authority granted to the College's Project Manager by the College, no acts performed or representations, whether oral or written, made by or with respect to third parties and the Contractor shall be binding on the College.

11.3. EQUAL OPPORTUNITY

11.3.1. During the performance of this Contract, and in accordance with applicable law, the Contractor shall not discriminate in any manner on the basis of age, sex, race, color, religious belief, national origin, creed, status as a qualified individual with a disability or handicap, pregnancy, marital status or status as a disabled veteran or veteran of the Vietnam era.

11.3.2. The Contractor shall take affirmative action to ensure that applicants are employed, and that employees are treated equally during employment without regard to their age, sex, race, color, religious belief, national origin, creed, status as a qualified individual with a disability or handicap, pregnancy, marital status or status as a disabled veteran or veteran of the Vietnam era. Such action shall include, but not be limited to the following: employment, upgrading, demotion, or transfer; recruitment or recruitment advertising; layoff or termination; rates of pay or other forms of compensation; and selection for training apprenticeship. The Contractor agrees to post in conspicuous places, available to employees and applicants for employment, notices setting forth the provisions of this non-discrimination clause.

11.3.3. During the performance of this contract, the Contractor agrees that it shall, in all solicitations or advertisements for employees placed by or on behalf of the Contractor, state that all qualified applicants shall receive consideration for employment without regard to sex, race, age, color, creed, national origin, religious belief, handicap, marital status or status as a disabled veteran or veteran of the Vietnam era. The Contractor further assures the College that, in accordance with the Immigration Reform and Control Act of 1986, it does not and will not discriminate against an individual with respect to hiring, or recruitment or referral for a fee, of the individual for employment or the discharging of the individual from employment because of such individual's national origin or in the case of a citizen or intending citizen, because of such individual's citizenship status.

11.3.4. The Contractor shall comply with all provisions of Executive Order 11246, as amended and of the rules, regulations and relevant orders of the Secretary of Labor.

11.3.5. The Contractor shall furnish all information and reports required by Executive Order 11246, as amended and by the rules, regulations and orders of the Secretary of Labor, or pursuant thereto, and shall permit access to the Contractor's books, records and accounts by the contracting agency and the Secretary of Labor for purposes of investigation to ascertain compliance with such rules, regulations and orders.

11.3.6. In the event of the Contractor's noncompliance with the nondiscrimination clauses of the Contract or with any of such rules, regulations or orders, this contract may be canceled, terminated or suspended in whole or in part, or the College may take such other action as may be necessary to obtain compliance. If such noncompliance appears continuing, the College may suspend all Contract payments until the noncompliance has ceased. Any delay in completion of the Contract as the result of the College taking action to obtain compliance with the nondiscrimination clauses of this Contract shall not preclude the imposition and collection of the liquidated damages for each day of delay in completion of the Work as provided for elsewhere in the Contract Documents. The Contractor may also be declared ineligible for further contracts with the College in accordance with procedures authorized in Executive Order 11246, as amended. The

College's conceptual rights and remedies provided under this section are in addition to any other rights and remedies as provided in Executive Order 11246, as amended or by rule, regulation or order of the Secretary of Labor, or as otherwise provided by law or under this Contract.

11.3.7. Subcontractors shall not be approved by the College without first agreeing to the above terms and conditions, and the Contractor shall include the provisions of subsections (1) through (7) of this section in every subcontract or purchase order unless exempted by rules, regulations or orders of the Secretary of Labor issued pursuant to Section 204 of Executive Order 11246, as amended, so that such provisions shall be binding upon each Subcontractor or vendor. The Contractor shall take such action with respect to any Subcontractor or purchase order as the College may direct as a means of enforcing such provisions including sanctions for noncompliance; provided, however, that in the event the Contractor becomes involved in, or is threatened with, litigation with a Subcontractor or vendor as a result of such direction by the College, the Contractor may request the United States to enter into such litigation to protect the interests of the United States.

11.4. COMPLIANCE WITH THE IMMIGRATION REFORM AND CONTROL ACT OF 1986

11.4.1. The Contractor warrants that both the Contractor and/or any subcontractor of the Contractor do not and shall not hire, recruit or refer for a fee, for employment under this Agreement or any subcontract, an alien knowing the alien is an unauthorized alien and hire any individual without complying with the requirements of the Immigration Reform and Control Act of 1986 (hereinafter referred to as "IRCA"), including but not limited to any verification and record keeping requirements. The Contractor agrees to indemnify and save the College, its employees and/or trustees harmless from any loss, costs, damages or other expenses suffered or incurred by the College, its employees and/or trustees by reason of the Contractor's or any subcontractor of the Contractor's noncompliance with "IRCA." The Contractor agrees to defend the College, its employees and/or trustees in any proceeding, action or suit brought against the College, including but not limited to administrative and judicial proceedings, arising out of or alleging noncompliance of the Contractor with "IRCA." The Contractor recognizes that it is the Contractor's responsibility to ensure that all certifications and verifications as required by law are obtained and maintained for the applicable time period.

11.5. ASSURANCE OF NONCONVICTION OF BRIBERY

11.5.1. The Contractor hereby declares and affirms that, to its best knowledge, none of its officers, directors or partners and none of its employees directly involved in obtaining contracts has been convicted of bribery, attempted bribery or conspiracy to bribe under the laws of any state or the Federal Government.

11.6. CONFLICT OF INTEREST

11.6.1. No employee of the College or of the State of Maryland, or any department, commission, agency or branch thereof whose duties as such employee include matters relating to or affecting the subject matter of this Agreement shall, until such time as the Contractor receives final payment, become or be an employee of the party or parties hereby contracting with the College, the State of Maryland, or any department, commission, agency or branch thereof.

11.7. ASSIGNMENT AND SUBCONTRACTING

11.7.1. Neither the College nor the Contractor shall sell, transfer, assign or otherwise dispose of this Agreement or any portion thereof, or its right, title or interest therein, or its obligations there under, without the written consent of the other. A change in membership of the Contractor's firm of one or more officers shall not constitute an assignment.

11.7.2. The Contractor shall not make any contracts for professional services with any other party for furnishing any of the work or services to be performed under this Agreement without the written approval of the College; however, this provision shall not be taken as requiring the approval of the contract of employment between the Contractor and its personnel assigned for the purposes of performing this

Agreement.

11.8. CONTINGENT FEES

11.8.1. The Contractor hereby declares and affirms that neither it nor any of its representatives has employed or retained any person, partnership, corporation, or other entity, other than a bona fide employee or agent working for the Contractor, to solicit or secure this Agreement, and that it has not paid or agreed to pay any person, partnership, corporation, or other entity, other than a bona fide employee or agent, any fee or any other consideration contingent on the making of this Agreement.

11.9. MARYLAND PUBLIC INFORMATION ACT

11.9.1. The College is subject to the Maryland Public Information Act, Title 10 of the State Government Article of the Annotated Code of Maryland. Contractor agrees that it will provide any justification as to why any material, in whole or in part, is deemed to be confidential, proprietary information or secrets and provide any justification of why such materials should not be disclosed pursuant to the Maryland Public Information Act.

11.10. TESTING AND INSPECTION

11.10.1. The College may retain, or may require the Contractor to retain, the services of testing/inspection laboratories/firms to perform the tests and make the required inspections and reports during the course of the Work as specified in the various sections of the Specifications or as required by the College in case of questions as to the strength or suitability of materials. However, for the purpose of preparing and testing design concrete mixes, the Contractor will retain the services of a testing laboratory which shall be other than that retained by the College. The Contractor shall also be responsible for all tests as indicated in the Specifications.

11.10.2. Testing/inspection laboratories/firms shall be responsible for conducting and interpreting the tests, shall state in each report whether or not the specimens tested conform to all requirements of the Contract Documents and shall specifically note deviations, if any, from said requirements. All testing/inspection laboratories/firms shall be subject to the College's approval.

11.10.3. The cost of testing services required solely for the convenience of the Contractor in its scheduling and performance of the Work, and the cost of testing services related to remedial operations performed to correct deficiencies in the Work shall be borne by the Contractor.

11.10.4. The Contractor shall furnish to the College's Project Manager samples of all materials and component parts of the Work required as test specimens in connection with the specified tests, and shall furnish labor and facilities at the site as necessary in connection with testing and inspection services whether such services are performed at the expense of the College or the Contractor.

11.10.5. The nature and scope of testing services performed by an agency retained by the Contractor shall be in accordance with requirements of governing authorities having jurisdiction over the Work and as otherwise specified, and shall be consistent with reasonable standards of engineering practice.

11.10.6. If, in the performance of any testing, control, balancing, adjusting or similar activities to be performed by the Contractor or an agent of the Contractor, it is the opinion of the College's Project Manager that the Contractor or said agent has failed to substantiate its ability to perform such work, the Contractor shall, at its expense, retain the services of a testing laboratory or service organization which is satisfactory to the College's Project Manager for the performance of such work.

11.11. NO WAIVER OF RIGHTS – COLLEGE'S REMEDIES CUMULATIVE – COLLEGE'S DAMAGES

11.11.1. The College shall not be precluded or estopped by any measurement, estimate, change order, contract modification, certificate of payment, or payment from showing the true amount and character of the

Work furnished by the Contractor, or from showing that any measurement, estimate, change order, contract modification, certificate of payment, or payment is untrue or was incorrectly made, or from showing that the Work does not in fact conform to the Contract Documents. The College may recover from the Contractor or its sureties, or both, such damages, loss or additional expense incurred as a result of any such error or measurement, estimate, change order, contract modification, certificate of payment, or payment as a result of such failure to conform to the Contract Documents. The College's right in this respect shall not be waived or barred by any inspection, acceptance or approval of the Work, or by payment therefore, or by granting an extension of time, or by taking possession, or by execution of a change order based on the erroneous measurement, estimate, or change order, contract modification, certificate of payment or payment.

11.11.2. The activities of the College's Project Manager, Architect/Engineer and the College respecting this Contract, including inspection of the Work, review of submittals, monitoring of progress, and so forth, are for the benefit of the College only and are not for the benefit of the Contractor. The College's failure to bring to the attention of the Contractor deficiencies in the Work or in the Contractor's performance will not constitute a waiver or excuse of the Contractor's failure to comply strictly with contract requirements.

11.11.3. The waiver by the College of any breach of contract by the Contractor shall not operate as a waiver of any other or subsequent breach.

11.11.4. The rights and remedies of the College and the obligations of the Contractor under various provisions of the Contract Documents and under provisions of the law are cumulative and not exclusive.

11.11.5. For any claim or cause of action accruing to the College as a result of or arising out of this Contract, the College may collect damages of any kind, including consequential damages, or damages for purely economic loss.

11.12 REGISTRATION FOR CORPORATIONS NOT INCORPORATED IN THE STATE OF MARYLAND

Pursuant to 7-201 et seq. of the Corporation and Associations Article of the Annotated Code of Maryland, corporations not incorporated in the State of Maryland shall be registered with the State Department of Assessments and Taxation, 301 West Preston Street, Baltimore, Maryland 21201, before doing any interstate or foreign business in this State. By signing this agreement, the Contractor certifies that it has qualified with the Department of Assessments and Taxation.

ARTICLE 12 – TERMINATION OF THE CONTRACT

12.1. TERMINATION FOR DEFAULT

12.1.1. The performance of the Work or services under this Contract may be terminated by the College, in whole or in part, from time to time, effective upon receipt of notice, whenever the Contractor shall default in the performance of this Agreement and fails to make progress in the prosecution of the contract work or endangers such performance and shall fail to cure such default within ten (10) calendar days period after receipt of written notification from the College specifying the default.

12.1.2. The College may terminate the Contract if the Contractor;

12.1.2.1. persistently or repeatedly refuses or fails to supply enough properly skilled Workers or materials;

12.1.2.2. fails to make payment to Subcontractors for materials or labor in accordance with their respective agreements between the Contractor and the Subcontractors;

12.1.2.3. persistently disregards laws, ordinances, or rules, regulations or orders of a public authority having jurisdiction;

12.1.2.4. refuses or fails to prosecute the Work, or any separable part thereof with such diligence as shall ensure its completion within the time specified in the Contract or in the extension thereof;

12.1.2.5. fails to complete the Work within the time allotted by the Contract; or

12.1.2.6. is in breach of any material obligation of the Contract, including a breach which may occur after Substantial Completion.

12.1.3. If any of the above reasons exist, the College may without prejudice to any other rights or remedies of the College and after giving the Contractor and the Contractor's surety, if any, seven days written notice, terminate the employment of the Contractor and may, subject to any rights of the surety:

12.1.3.1. take possession of the site and all materials, equipment, tools, and construction equipment and machinery owned by the Contractor; and

12.1.3.2. finish the Work by whatever reasonable means the College may deem is in its interests.

12.1.4. When the College terminates the Contract for one of the reasons stated herein, the Contractor shall not be entitled to receive any further payment until the Work is finished. If the unpaid balance of the Contract Sum exceeds the cost to finish the Work, such excess shall be applied to the Contractor's unreimbursed costs, if any, accrued from the last payment prior to termination to time of termination. This amount shall become due to the Contractor. Any unreimbursed costs exceeding the difference of unpaid balance of the Contract Sum and the cost to finish the Work shall be lost to the Contractor. If the cost to finish the Work exceeds the Contract Sum, the Contractor shall pay the difference to the College. The amount to be paid to the Contractor or College, as the case may be, shall survive termination of the Contract.

12.2. TERMINATION FOR CONVENIENCE

12.2.1. The College may, at any time, terminate the Contract in whole or in part for the College's convenience and without cause.

12.2.2. Upon receipt of written notice from the College of such termination for the College's convenience, the Contractor shall (1) cease operations as directed by the College in the notice; (2) take actions necessary, or that the College may direct, for the protection and preservation of the Work; and (3) except for Work directed to be performed prior to the effective date of termination stated in the notice, terminate all existing subcontracts and purchase orders and enter into no further subcontracts and purchase orders.

12.2.3. In the case of such termination for the College's convenience, the Contractor shall be entitled to receive payment from the College for all expenses incurred by it for satisfactory work, including reasonable termination expenses. Upon satisfactory proof that the Contractor would have earned a profit for Work performed prior to the date of termination, the Contractor shall be paid a reasonable amount for profit not to exceed 10% of the Contractor's costs incurred. Under no circumstances shall the Contractor be entitled to payment for anticipated but unearned profit, overhead, and damages. In no event shall the Contractor's cost of the Work and profit, if any, to be reimbursed exceed the Contract Sum as adjusted by approved change orders.

END OF GENERAL CONDITIONS

SUPPLEMENTARY CONDITIONS OF THE CONTRACT

PART 1 - COMPLEX STRUCTURES

- 1.1. Section 007200, General Conditions of the Contract, Paragraph 3.1.2. Montgomery County Complex Structures process does not apply to this project.

PART 2 – PROJECT PROCEDURES

- 2.1 The Contractor shall coordinate with the College regarding site access.
- 2.2 The Contractor shall submit a COVID-19 safety plan laying out procedures and protocols for keeping employees and College personnel safe.
- 2.3 The Contractor shall share site access and project site with other contractors performing work concurrently.
- 2.4 The Contractor shall accommodate mid-terms and final exams in the schedule and refrain from any noisy or disruptive work during this time. The College shall determine time frame for mid-term and final examinations.

END OF SUPPLEMENTARY CONDITIONS

REV.	ISSUE	DATE



PROFESSIONAL CERTIFICATION
I CERTIFY THAT THESE DOCUMENTS WERE PREPARED OR
APPROVED BY ME, AND THAT I AM A FULLY LICENSED PROFESSIONAL
ENGINEER UNDER THE LAWS OF THE STATE OF MARYLAND.
LICENSE NUMBER 24086, EXPIRATION DATE 02-01-2021

**NEW STAIR PLANS
AND DETAILS**

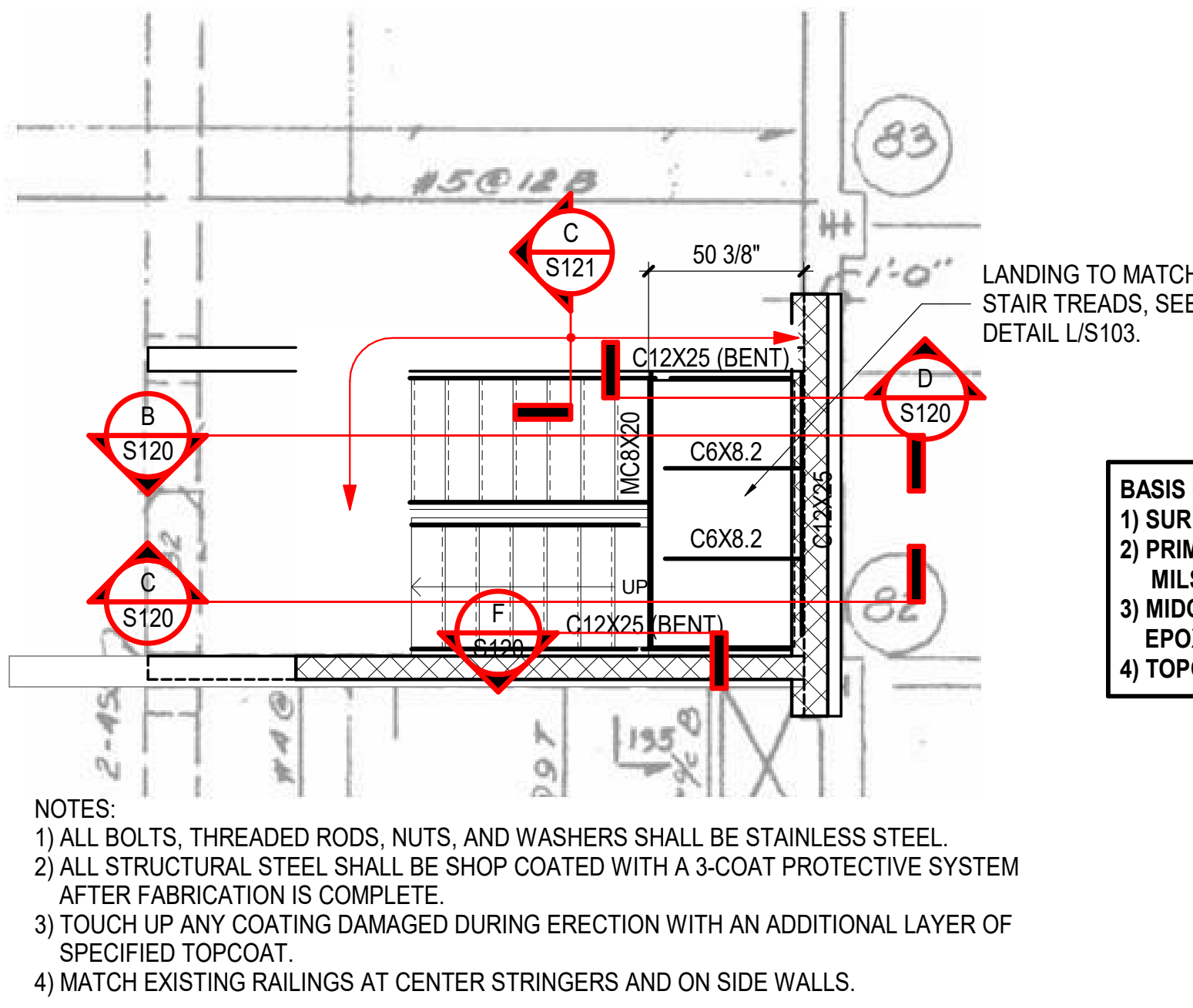

(A) NEW STAIR FRAMING REFERENCE PLAN
1 1/2" = 1'-0"

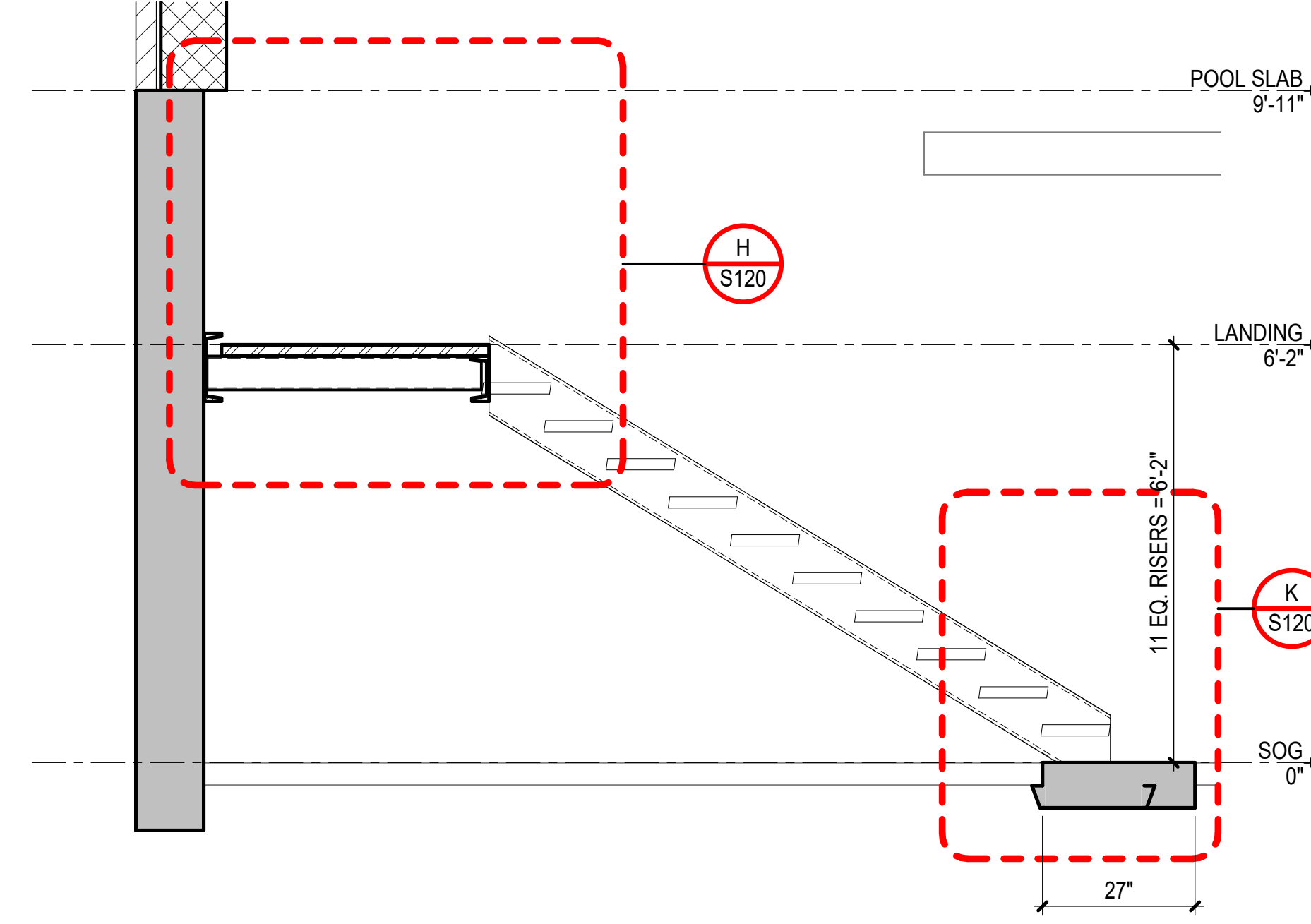

(B) STAIR ELEVATION DETAIL
1/2" = 1'-0"

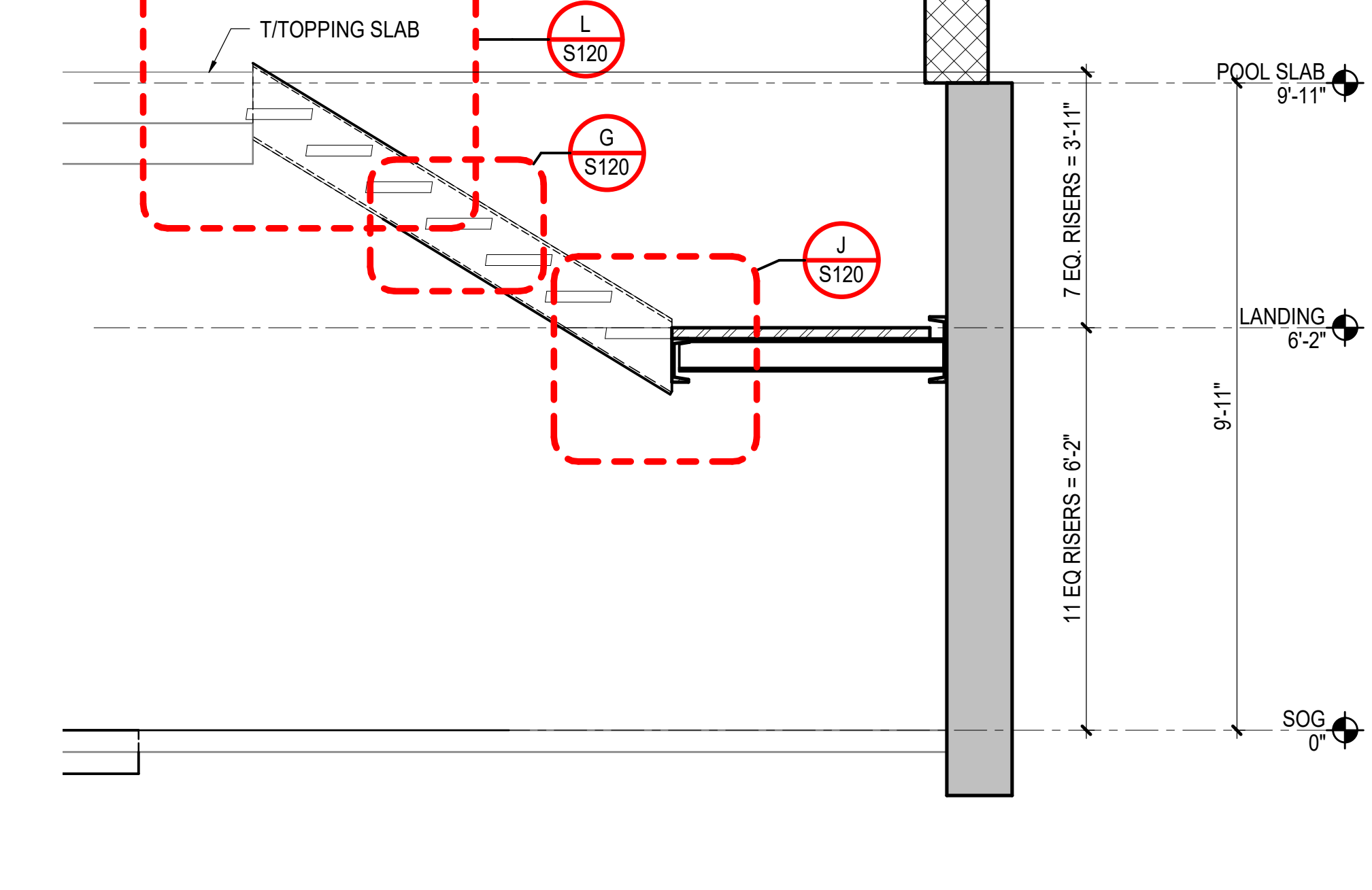

(C) STAIR ELEVATION DETAIL
1/2" = 1'-0"

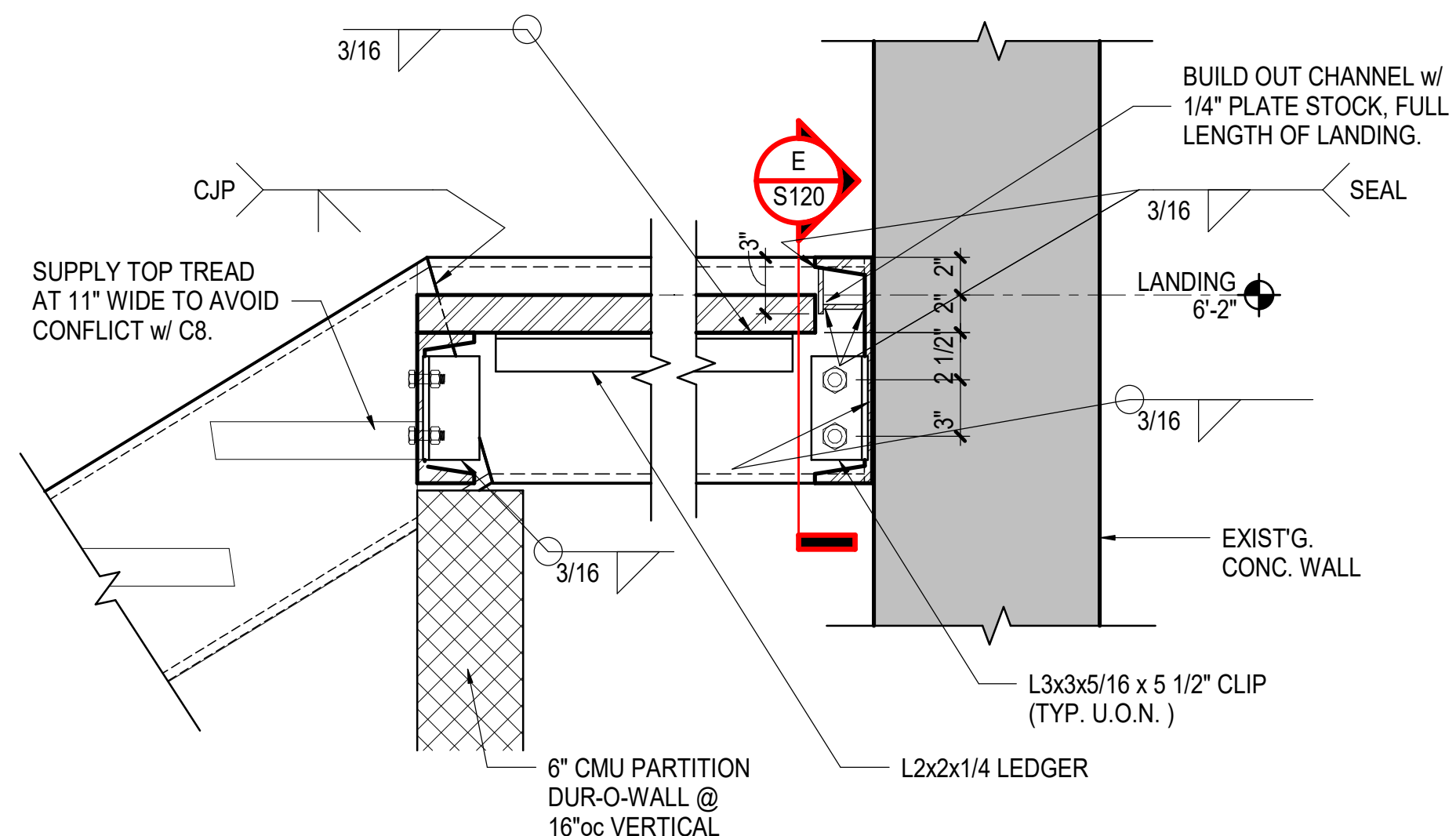

(D) STAIR LANDING LOW STRINGER CONN.
1 1/2" = 1'-0"

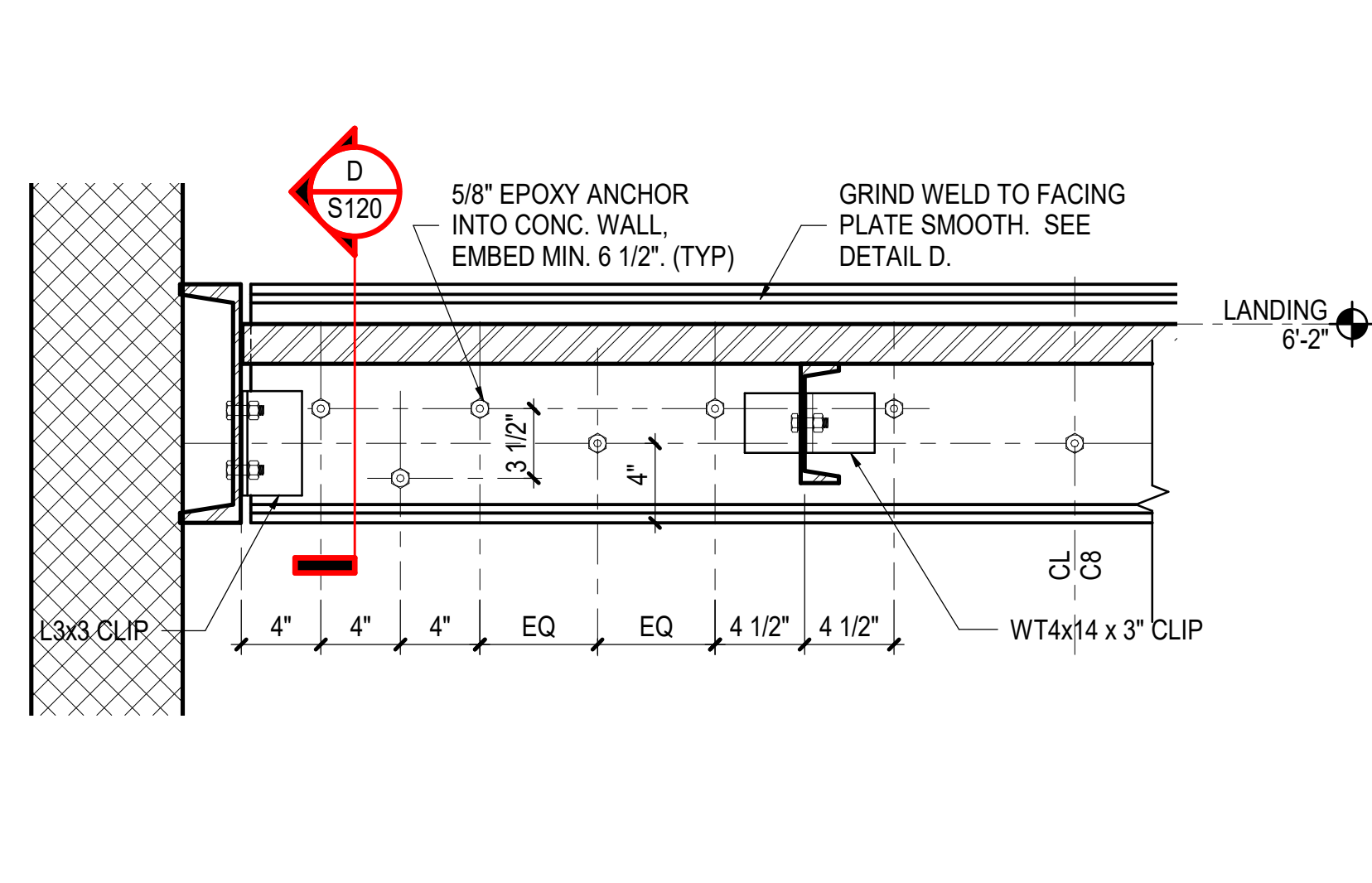

(E) STAIR LANDING BACK CONN. DETAIL
1 1/2" = 1'-0"

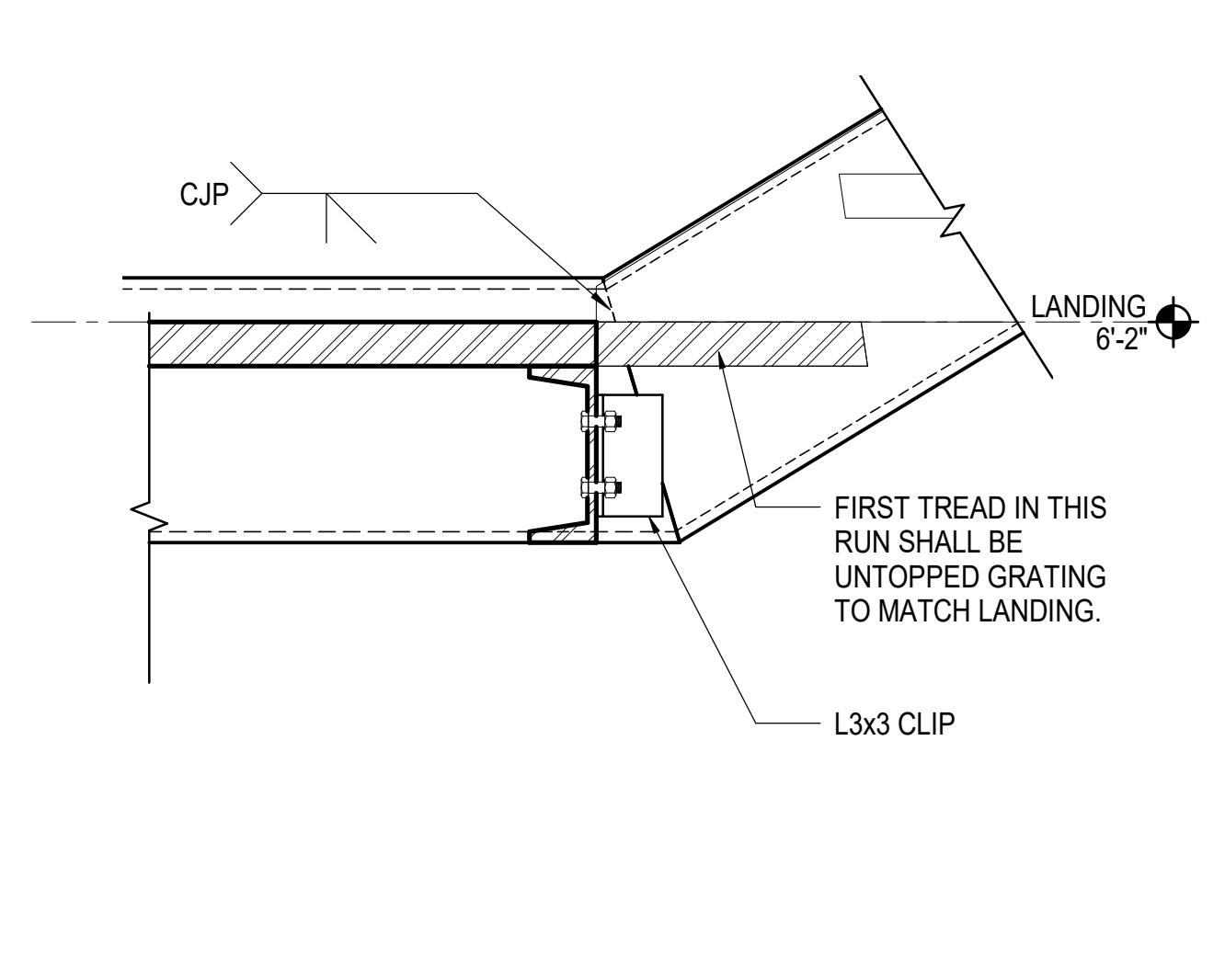

(F) STAIR LANDING HIGH STRINGER CONN.
1 1/2" = 1'-0"

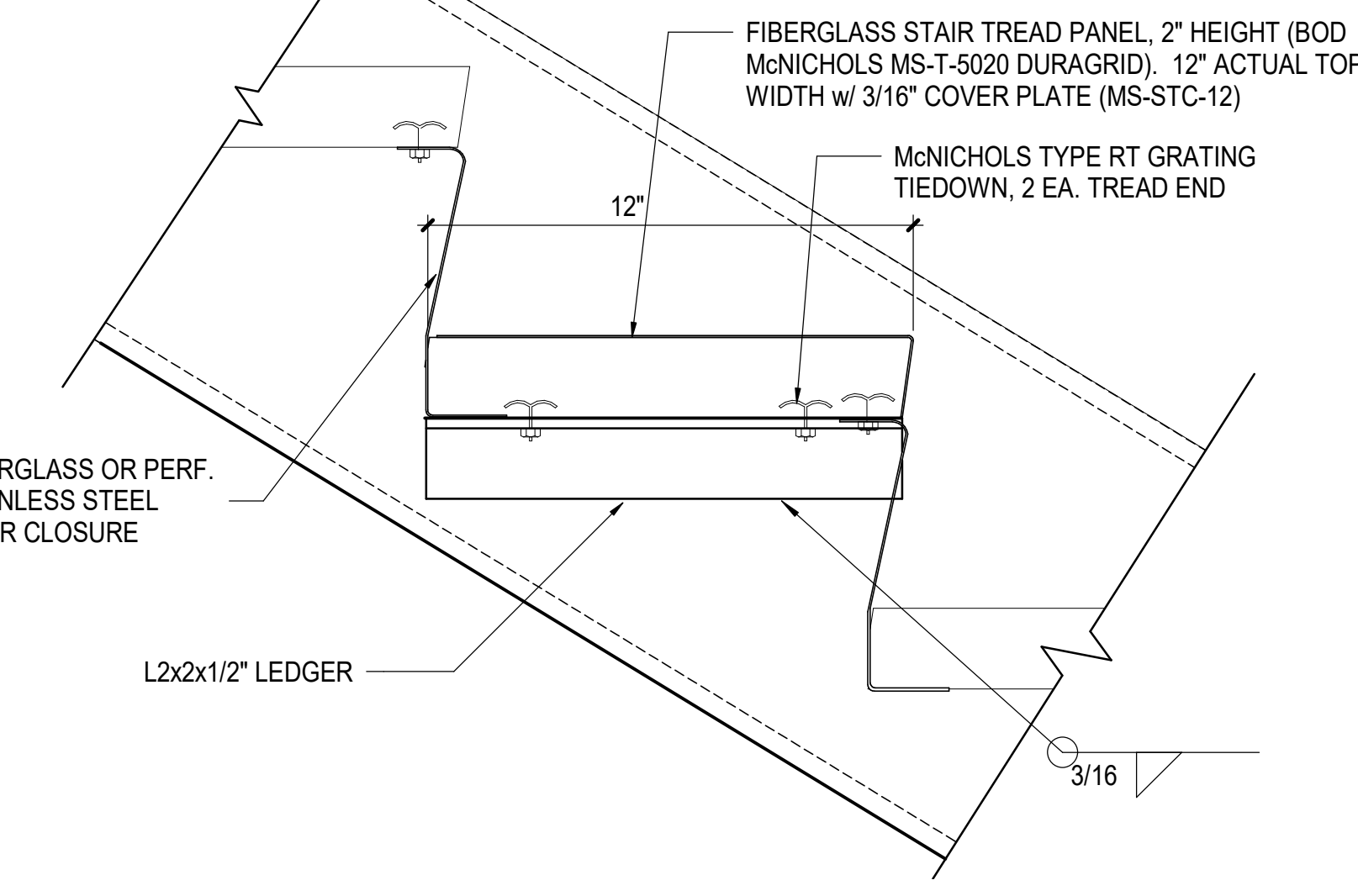

(G) STAIR TREAD CONN. DETAIL
3\"/>

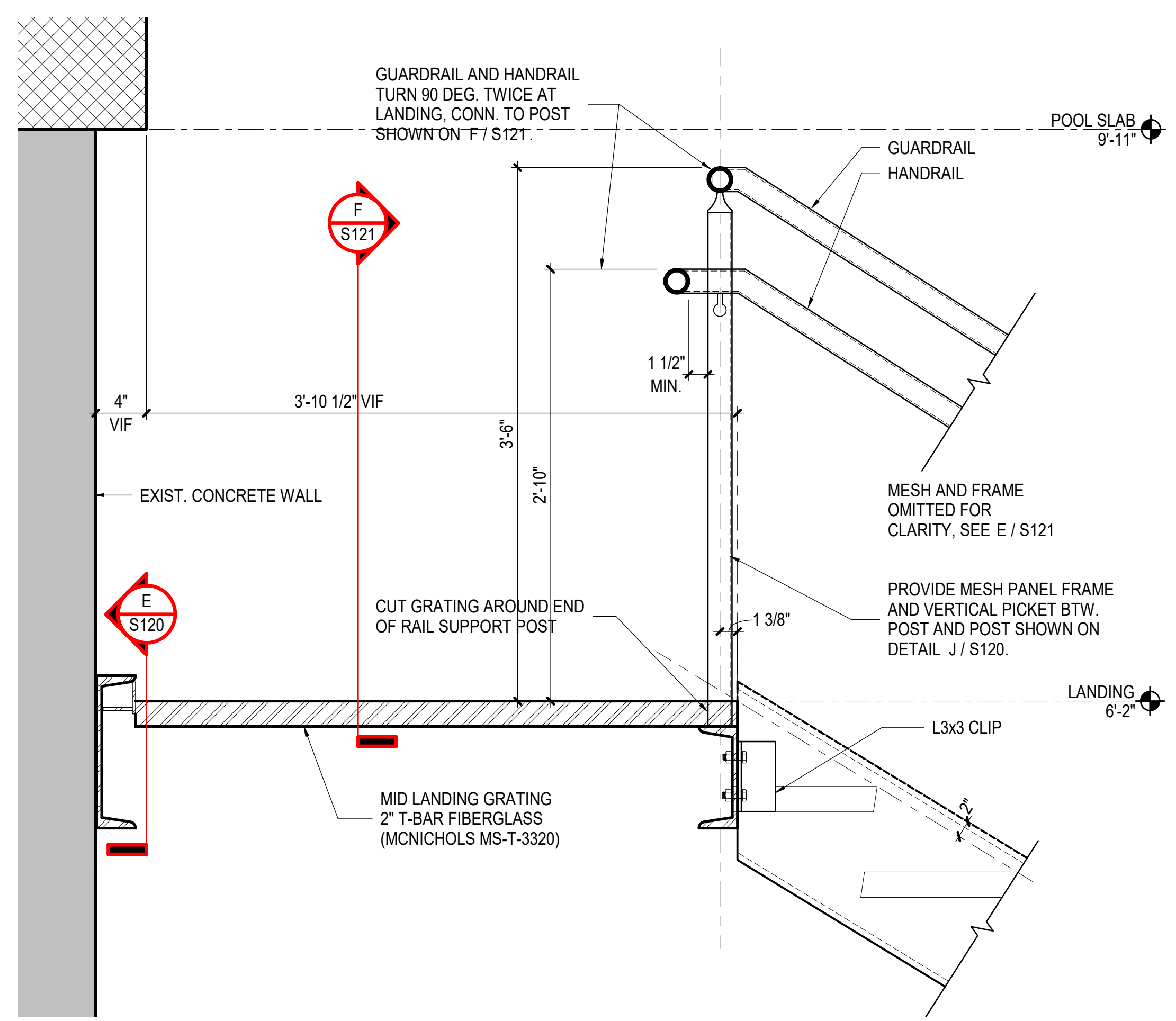

(H) INTERIOR LOW STRINGER CONN.
1 1/2" = 1'-0"

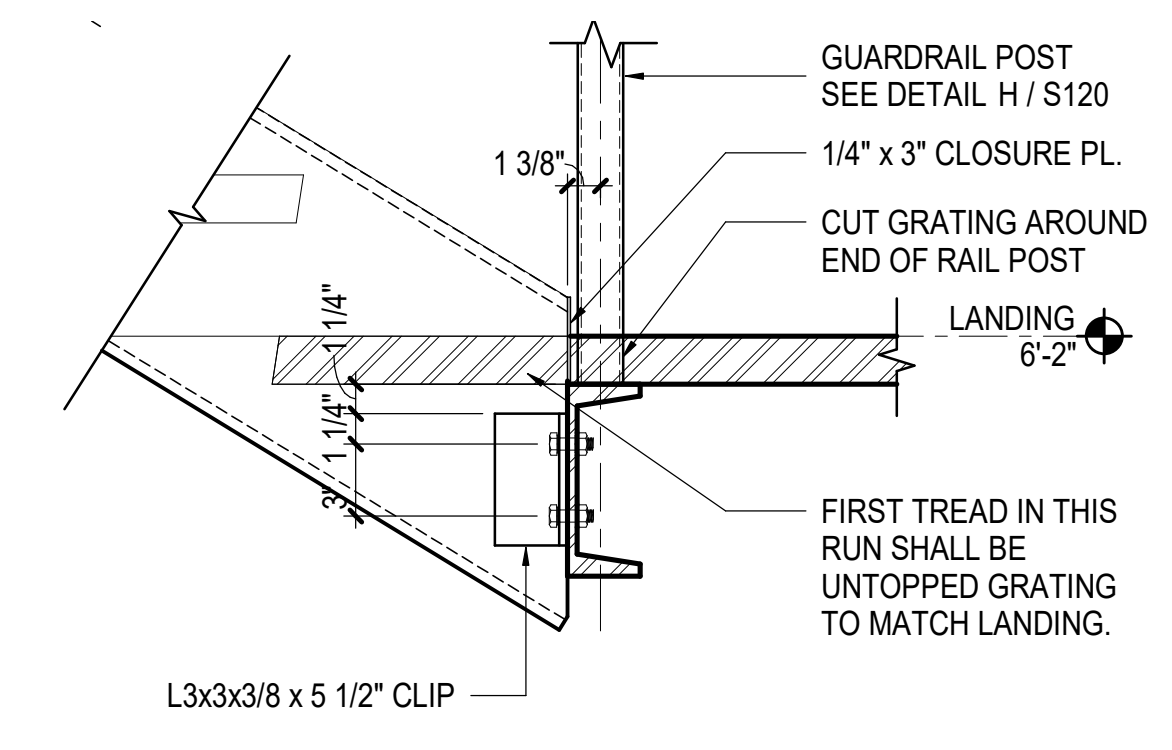

(J) INTERIOR HIGH STRINGER CONN.
1 1/2" = 1'-0"

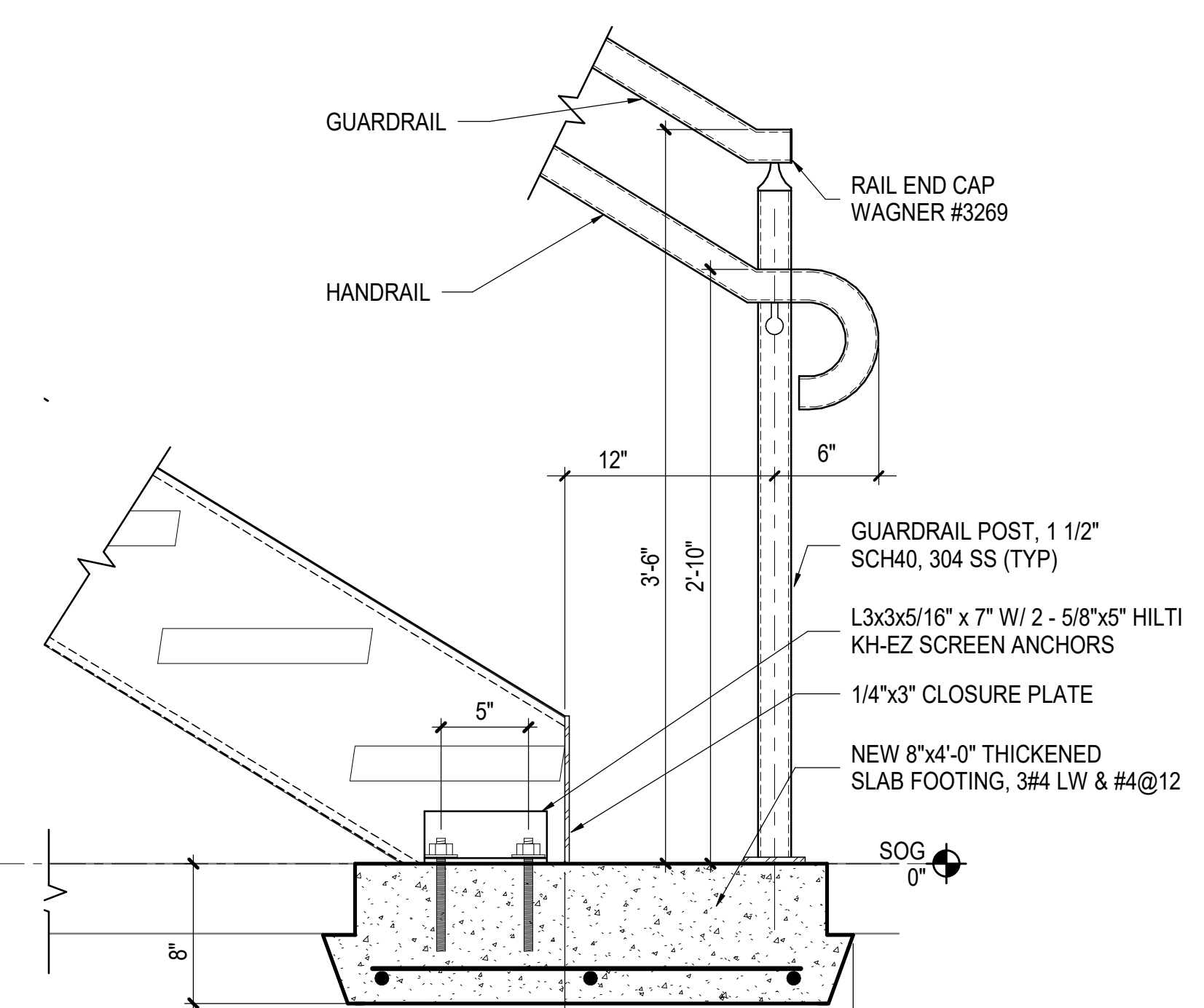

(K) STRINGER BASE CONN. DETAIL
1 1/2" = 1'-0"

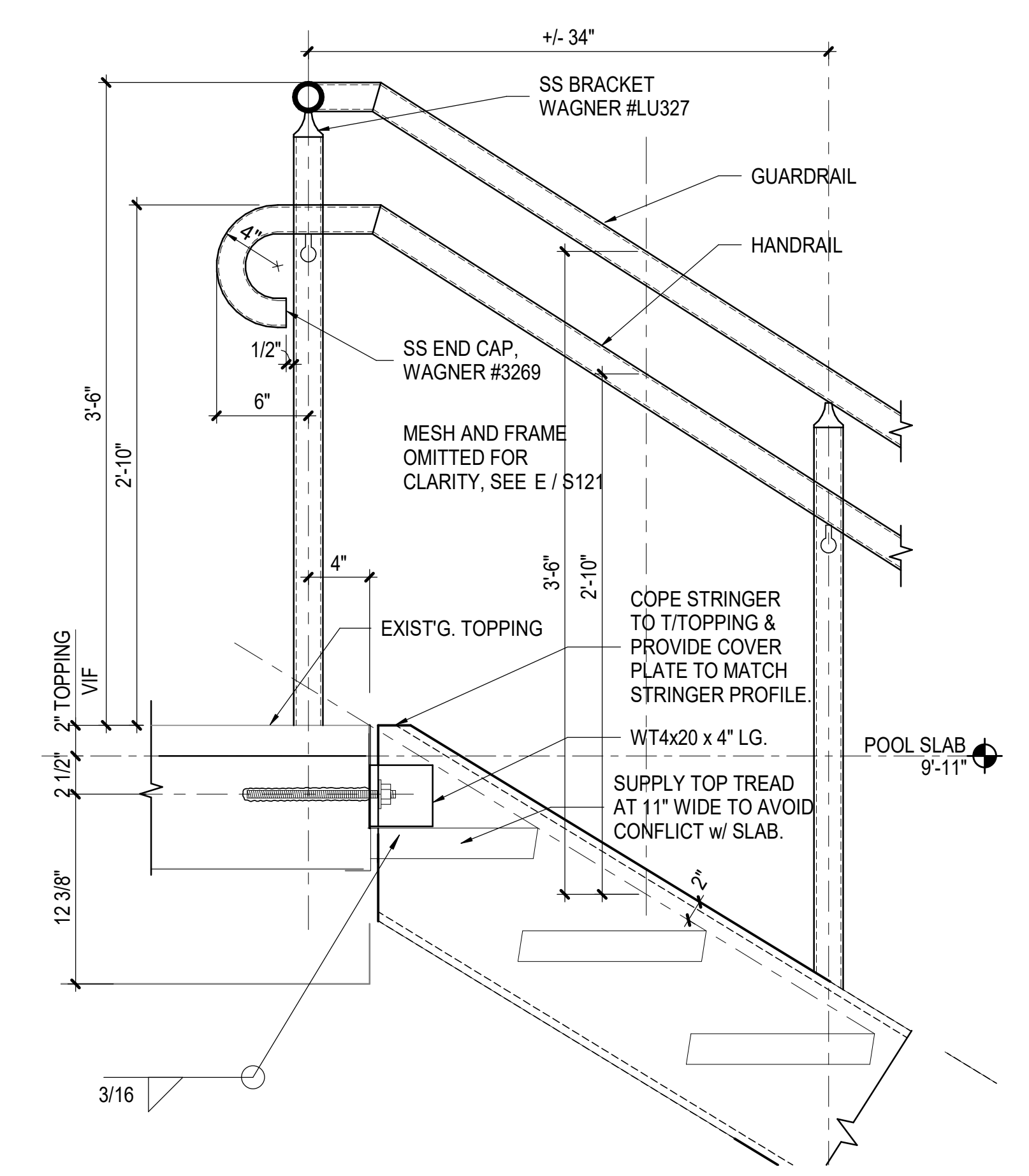

(L) STRINGER CONN. TO DECK SLAB
1 1/2" = 1'-0"

P:\PROJECTS\16014.23\16014.23.dwg 01/20/2021 14:52:15

